

Typenschlüssel

Fan type code

RVS 225 -2/2 E	Motorversion / <i>Motor type</i>
	E = Einphasenwechselstrom <i>Single-phase A.C.</i>
	D = Drehstrom <i>Three-phase A.C.</i>
	Polzahl / <i>Number of poles</i>
	Nennweite <i>Impeller diameter</i>
	mit integrierter Schalldämmhaube <i>with built-in sound attenuation hood</i>
	Ausführung / <i>Discharge orientation</i>
	H = Horizontal ausblasend <i>horizontal discharge</i>
	V = vertikal ausblasend <i>vertical discharge</i>
	Dachventilator / <i>Roof fan</i>



4

Eigenschaften und Ausführung

Wolter Dachventilatoren eignen sich zum Aufbau auf Flach-, Pult-, Sattel-, Bogen- und Shed-Dächern. Man unterscheidet zwischen:

- ▶ **horizontal ausblasenden Dach-Ventilatoren RH**
für die Absaugung weniger stark verunreinigter Luft und
- ▶ **vertikal ausblasenden Dach-Ventilatoren RV**
für die Absaugung stärker verschmutzter Luft

Gehäuse

- RH** Haube bis Baugröße 500 aus seewasserbeständigem Aluminium, ab Baugröße 560 aus verzinktem Stahlblech.
- RV** Gehäuse aus seewasserbeständigem Aluminium.
- RVS** mit integrierter Schalldämmhaube.

Lauftrad

Die rückwärtsgekrümmten Laufräder sind direkt auf die Rotoren der Außenläufermotoren aufgebaut und zusammen mit diesen entsprechend der Gütestufe G 2,5 nach DIN ISO 1940 auf 2 Ebenen gewuchtet.

Motor

Spannungssteuerbare Aussenläufermotoren in Schutzart IP44 (bis Baugröße 310L) bzw. IP 54 (ab Baugröße 355) mit Feuchteschutzimprägnierung und mit in der Wicklung eingebauten Thermokontakten.

Elektrischer Anschluß

Die Antriebsmotoren sind mit einem aufgebauten Anschlußkasten in Schutzart IP54 versehen, der für den elektrischen Anschluß nach Abnahme der Regenschutzhaube leicht zugänglich ist.

Montage

Wolter Dachventilatoren werden montagebereit ausgeliefert, jeweils in Einzelversandkartons oder Verschlägen.

Empfohlen wird die Verwendung von Flachdachsockeln aus unserem Zubehör-Programm. Sie sparen sich dadurch Kosten bei der Planung, bei der Ausführung und Montage. Sofern die Sockel bauseitig erstellt werden, so sind die von uns angegebenen Maße einzuhalten. Auf waagerechten Einbau und einwandfreie Abdichtung der Dachkante ist zu achten. Gegebenenfalls müssen Unebenheiten durch Distanzscheiben, Moosgummi oder ähnlich dichtendes Material behoben werden.

Luftleistungskennlinien

Die Kennlinien für diese Typenreihe wurden mittels einem saugseitigen Kammerprüfstand entsprechend der DIN 24 163 in der Einbautart A (frei ansaugend, frei ausblasend) aufgenommen. Sie zeigen die statische Druckerhöhung Δp_{st} (statisch, frei ausblasend) in Abhängigkeit des Volumenstroms. Die Bezugsdichte ist 1,2 kg/m³.

Schallentwicklung

Die Messung und deren Darstellung erfolgt nach DIN 45 635, Teil 38, gemäß dem dort beschriebenen Hüllflächenverfahren, nach dem über eine quaderförmige Meßfläche mehrere Meßpunkte erfasst werden. In den Kennlinienfeldern ist der **A-bewerteten Schalleistungspegel L_{WA}** in dB(A) angegeben, der dem **Frei-Ausblas-Schalleistungspegel L_{WAS}** entspricht.

Die Katalogangaben beziehen sich auf die Dachlüfter der Typenreihe RH. Bei den Ventilatoren der Typenreihe RV sind von den angegebenen Werten 2 dB(A) zu subtrahieren. Der Freiansaug-Schalleistungspegel L_{WAS} kann über die relativen Schalleistungspegel genau ermittelt, oder nach folgender Formel näherungsweise bestimmt werden:

$$L_{WAS} = L_{WA} - 3 \text{ dB}$$

Für genauere Berechnungen bei Schallschutzmaßnahmen ist der Schalleistungspegel der Oktavbänder von Bedeutung:

$$L_{Wokt} = L_{WA} + L_{Wrel}$$

Der austrittsseitige zu erwartende A-bewertete Schalldruckpegel kann nur annähernd ermittelt werden, da die Umgebungseinflüsse zu starken Abweichungen führen können:

$$L_{PA} = L_{WA} - \Delta L$$

Bei ungünstigen Verhältnissen kann das in der Anlage zustande kommende Geräusch von den Katalogangaben abweichen, etwa durch unterschiedliche Schallabsorption oder durch ungünstige Körperschallübertragung auf die Dachkonstruktion.

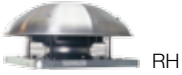

RH



RV, RVS

Pegelabnahme Halbkugel

Sound level reduction half sphere

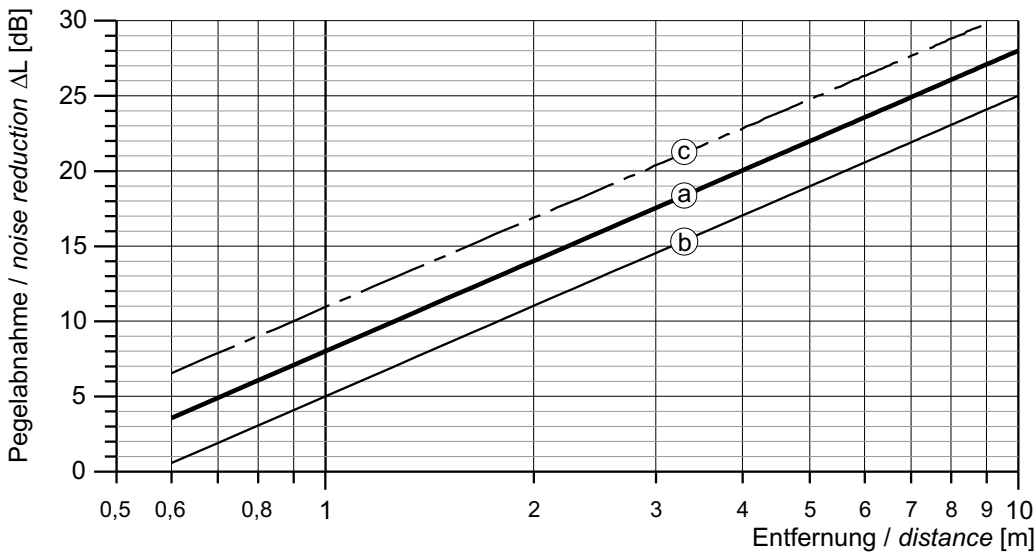

- a: ohne Reflexionen
without reflexion
- b: mit Reflexionen
with reflexion
- c: Vollkugel ohne Reflexionen
full sphere without reflexion

Types and design features

Wolter roof fan units are suitable for mounting on different roof types. There are two versions available:

- › **Type RH with horizontal discharge**
for the exhaust of mildly polluted air
- › **Type RV with vertical discharge**
for the exhaust of more heavily polluted air

Casing

- RH** up to size 500, the cowl is made of salt-water proof aluminium, from size 560 onwards, the cowl is manufactured from galvanised sheet steel
- RV** housing is made of salt-water proof aluminium
- RVS** with built-in sound attenuation hood

Impeller

The backward-curved impellers are mounted directly onto the rotor of the external rotor motors. The motorised impeller unit is balanced in two plains according to G 2,5 (DIN ISO 1940.)

Motor

Speed controllable external rotor motor, protection class IP44 (up to size 310L) or IP54 (from size 355), moisture-proof impregnation, thermal contacts mounted in motor winding.

Electrical connection

The motors are connected to a terminal box of protection class IP54, easily accessible after disassembly of the cowl.

Installation

All fans are delivered ready for installation and are packed in separate boxes or crates. We recommend the use of matching Wolter roof sockets. If other roof sockets are used, dimensions given in our catalogue should be followed to achieve proper sealing and avoid air-leakage.

Fan performance curves

The performance curves for these roof fans have been tested according to DIN 24 163. The curves indicate the static pressure increase Δp_{st} (static, free outlet) as a function of the volume flow. The reference air density is 1,2 kg/m³.

Sound levels

The sound data was measured according to DIN 45 635, part 38. The figures shown in the performance curves are the **A-weighted sound power levels (L_{WA})** in dB(A). They are equal to the **free outlet sound power level L_{WA5}** .

The catalogue data is valid for RH-type fans. In order to obtain the noise levels of RV series fans, reduce listed noise levels by **2 dB(A)**. The free inlet sound power level L_{WA5} can be calculated by the following approximation formula:

$$L_{WA5} = L_{WA} - 3 \text{ dB}$$

If sound protection measures require exact calculation, it is important to know the the sound power level of the octave band:

$$L_{Wokt} = L_{WA} + L_{Wrel}$$

The A-weighted sound pressure level at the outlet side can only be approximated, since environmental conditions will affect noise levels.

$$L_{PA} = L_{WA} - \Delta L$$

The actual noise levels will vary, depending on system characteristics such as reflexion, resonant frequencies or structure-borne noise transfer.

Sockelschalldämpfer SD

Der Sockelschalldämpfer kann anstelle des Flachdachsockels für die Montage des Lüfters verwendet werden. Er reduziert den Schallpegel im saugseitigen Kanalsystem.

Bei der Verwendung eines Sockelschalldämpfers sind die zusätzlichen Druckverluste zu berücksichtigen. Diese sind aus der nebenstehenden Grafik ersichtlich.

Socket silencer SD

A socket silencer can be used instead of the flat roof socket for mounting the fan. It reduces the sound propagation on the suction side.

When a socket silencer is used, additional pressure loss has to be taken into account. These can be found in the following diagram.

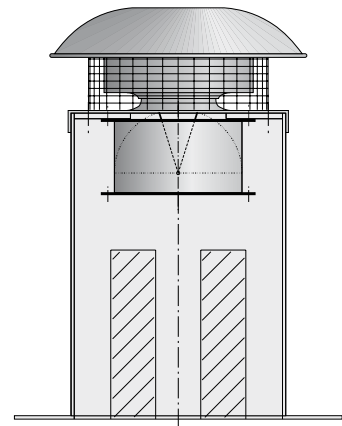

Druckverluste

Pressure losses

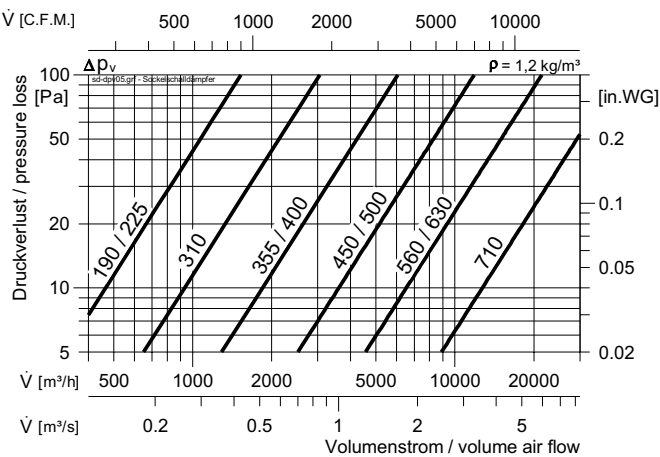

Dämpfungswerte

Attenuation capacity

Typ SD	Dämpfung [dB] bei Mittenfrequenz [Hz]						
	Attenuation [dB] at medium frequency [Hz]						
	125	250	500	1k	2k	4k	8k
190 / 225	5	8	12	18	22	20	14
310K / 310L	5	8	12	19	23	21	15
355 / 400	5	8	12	19	21	21	15
450 / 500	5	8	13	20	22	21	15
560 / 630	5	7	12	18	21	20	14
710	5	7	11	18	20	19	13

Integrierte Schalldämmhaube LVS

Die integrierte Schalldämmhaube der Lüfterbaureihe RVS ermöglicht es, den druckseitigen Schallpegel zu verringern. Diese Lüfterhaube hat im Vergleich zur normalen ungedämmten Haube (RV) etwas erhöhte Widerstände. Für exakte Berechnungen sind diese hier als Diagramm dargestellt.

Insulated sound attenuation cowl LVS

In order to reduce the sound emissions radiated from the roof fan, the use of a RVS attenuation cowl is recommended. Compared to the non-attenuated roof fan cowl (RV), the RVS cowl has slightly higher pressure losses. For exact calculations, these additional losses are shown in the following diagram.

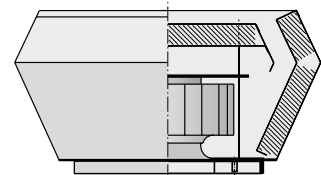

Druckverluste

Pressure losses

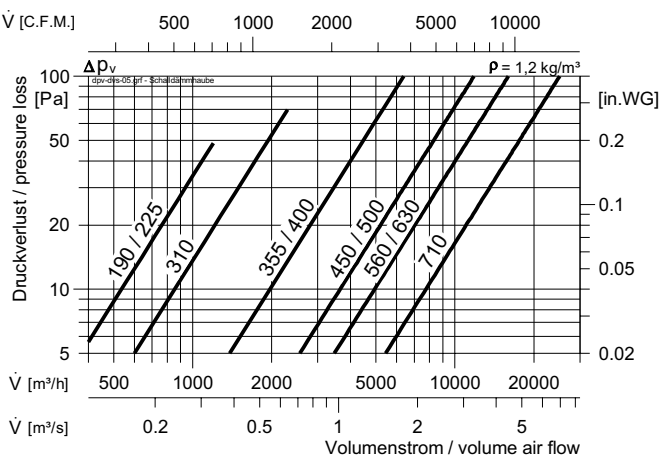

Dämpfungswerte

Attenuation capacity

Typ RVS / RHS	Dämpfung [dB] bei Mittenfrequenz [Hz]						
	Attenuation [dB] at medium frequency [Hz]						
	125	250	500	1k	2k	4k	8k
190 / 225	5	8	12	16	20	17	13
310K / 310L	5	8	12	17	20	17	14
355 / 400	5	8	11	16	19	16	13
450 / 500	5	8	12	17	20	17	14
560 / 630	5	8	11	16	19	16	13
710	5	7	10	16	18	16	12

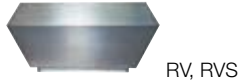
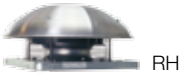

Dachhaube without motorised impeller LH / LV

Die leere Dachhaube kann zum Abschluß eines Kanalsystems verwendet werden. Sie hat je nach Lufrichtung unterschiedliche Druckverluste.

Roof cowl without motor LH / LV

The empty roof cowl can be used to close a ducted system on the inlet or outlet side. Depending on the direction of air flow, it has different pressure losses.

Ausblashaube

Outlet cowl

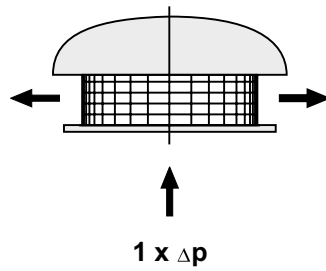
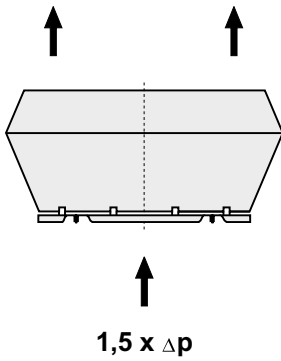

Druckverluste

Pressure losses

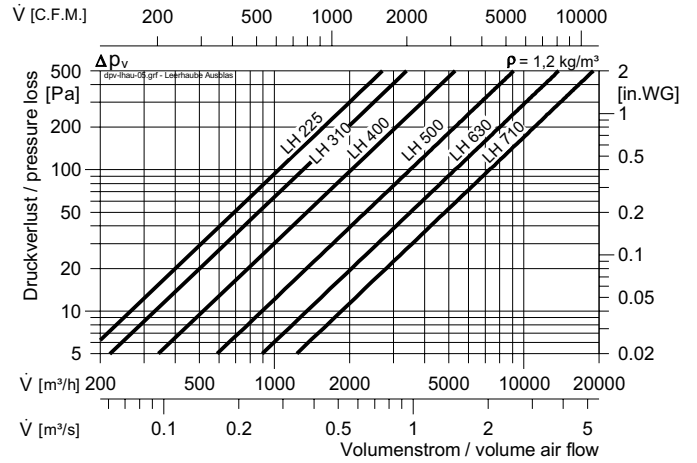

Ansaughaube

Inlet cowl

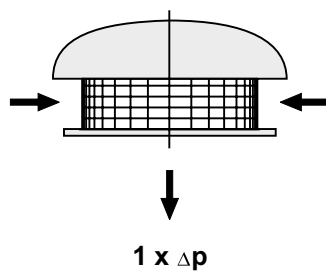
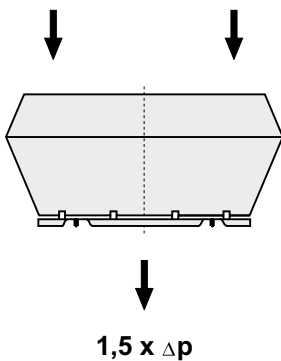

Druckverluste

Pressure losses

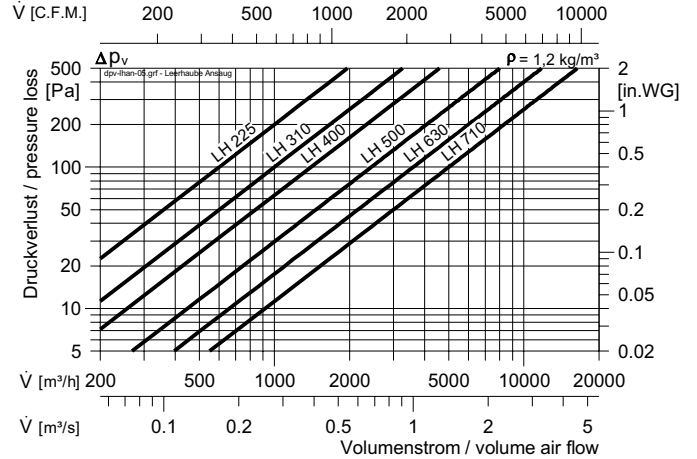

Abmessungen

Dimensions

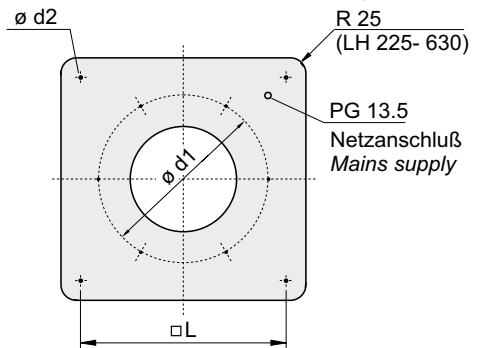
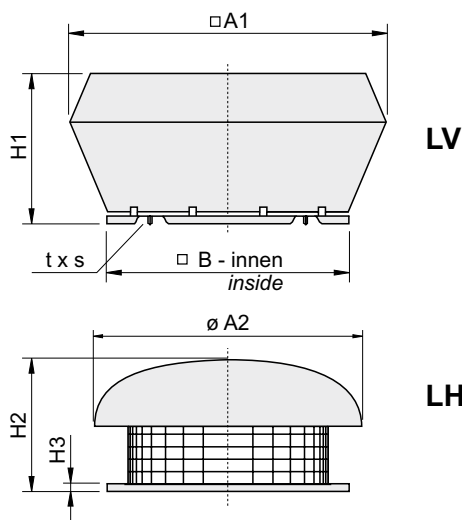

Größe size	A1 [mm]	A2 [mm]	H1 [mm]	H2 [mm]	H3 [mm]	B [mm]	L [mm]	d1 [mm]	d2 [mm]	t x s
225	370	370	170	140	30	335	245	213	10	6xM6
310	560	550	330	260	30	435	330	286	10	6xM6
400	720	720	400	340	30	595	450	438	12	6xM6
500	900	820	450	390	30	665	535	438	12	6xM6
630	1150	1100	570	460	30	939	750	605	14	8xM8
710	1350	-	680	-	40	1035	840	674	14	8xM8

RH / RV / RVS 190-2/2 E

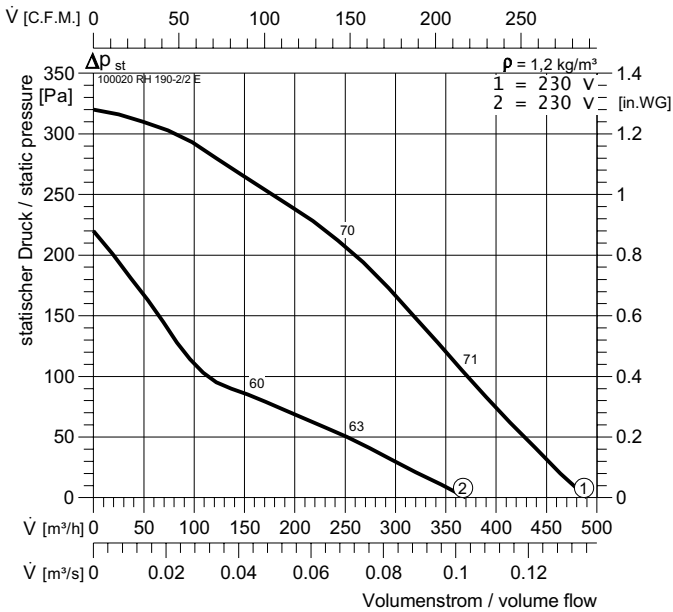

Typ	ArtNr		$L_{WA,rel}$ ΔdB	L_{WA5}	L_{WA8}
RH 190-2/2 E	100020	5 kg	$L_{WA,tot}$	-2	0
RV 190-2/2 E	102500	5,4 kg	125 Hz	-22	-22
RVS 190-2/2 E	100025	9,15 kg	250 Hz	-11	-9
U : 230 V 50 Hz	I_A / I_N : 1,4		500 Hz	-7	-6
P_1 : 0,07/0,04 kW		IP 44	1 kHz	-7	-6
I_N : 0,3/0,2 A		E14	2 kHz	-11	-6
n : 2420/1520 min ⁻¹		GS 1	4 kHz	-13	-11
C_{400V} : 2 μF		NE 0,5	8 kHz	-19	-15
t_r : 60 °C		RPE 02 A			

RH / RV / RVS 225-2/2 E

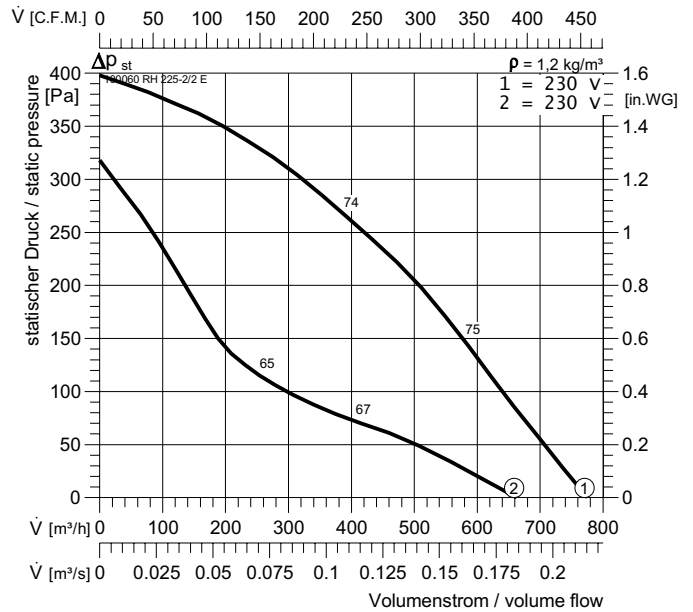

Typ	ArtNr		$L_{WA,rel}$ ΔdB	L_{WA5}	L_{WA8}
RH 225-2/2 E	100060	5,6 kg	$L_{WA,tot}$	-2	0
RV 225-2/2 E	102540	5,8 kg	125 Hz	-22	-22
RVS 225-2/2 E	100065	7,5 kg	250 Hz	-11	-9
U : 230 V 50 Hz	I_A / I_N : 1,7		500 Hz	-7	-6
P_1 : 0,11/0,08 kW		IP 44	1 kHz	-7	-6
I_N : 0,51/0,36 A		E14	2 kHz	-11	-6
n : 2580/1620 min ⁻¹		GS 1	4 kHz	-13	-11
C_{400V} : 3 μF		NE 1,5	8 kHz	-19	-15
t_r : 50 °C		RPE 02 A			

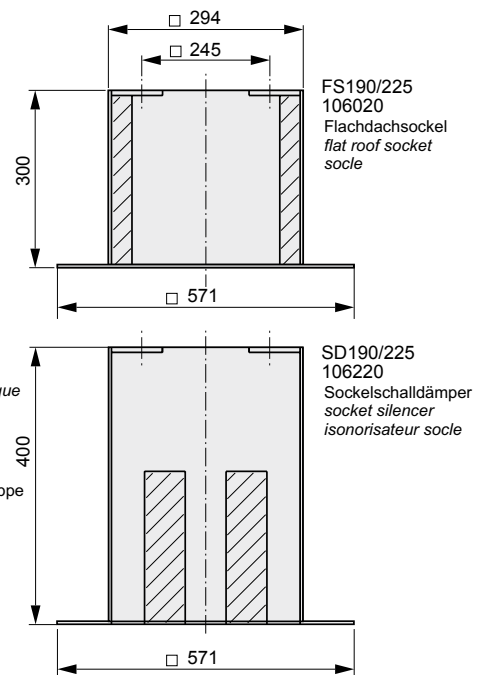
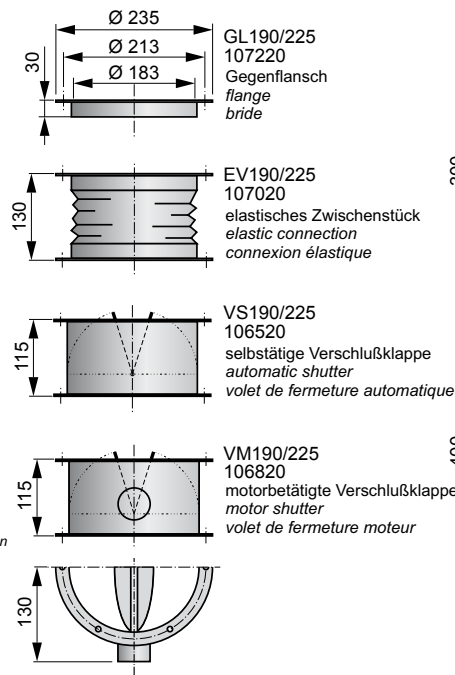
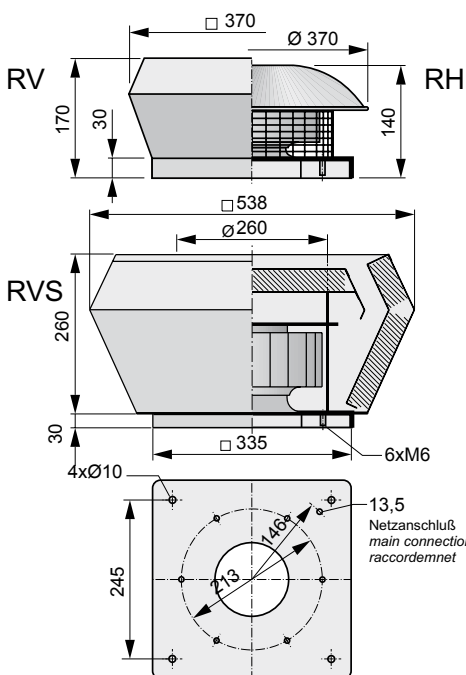



RH



RV, RVS

RH / RV / RVS 225-4/4 E

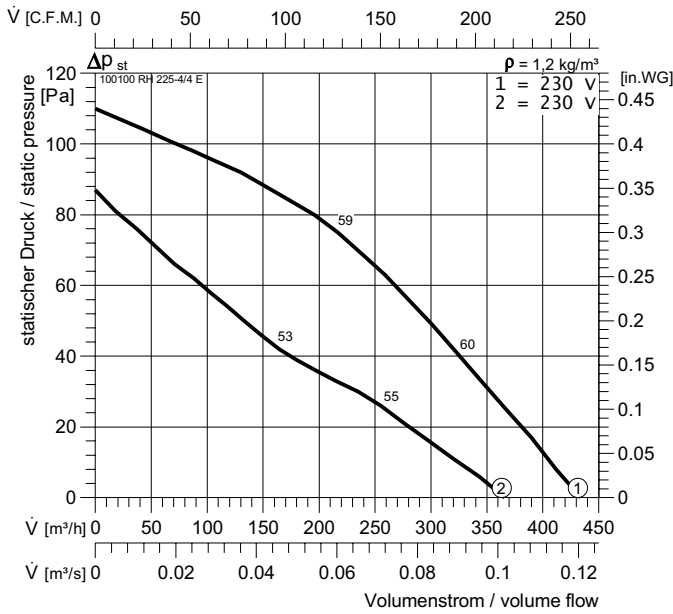

Typ	ArtNr	Icon	Weight	$L_{WA \text{ rel}} \Delta dB$	L_{WA5}	L_{WA8}
RH 225-4/4 E	100100	Icon	4,1 kg	$L_{WA \text{ tot}}$	-2	0
RV 225-4/4 E	102580	Icon	4,7 kg	125 Hz	-22	-22
RVS 225-4/4 E	100105	Icon	7,5 kg	250 Hz	-11	-9
U : 230 V 50 Hz	I_A / I_N : 1,4	Icon	500 Hz	-7	-6	
P_i : 0,04/0,02 kW	Icon	IP 44	1 kHz	-7	-6	
I_N : 0,16/0,1 A	Icon	E14	2 kHz	-11	-6	
n : 1320/1000 min ⁻¹	Icon	GS 1	4 kHz	-13	-11	
C_{400V} : 1,5 μF	Icon	NE 0,5	8 kHz	-19	-15	
t_R : 60 °C	Icon	RPE 02 A				

Kopfzeile

Typ	ArtNr	Icon	Weight	$L_{WA \text{ rel}} \Delta dB$	L_{WA5}	L_{WA8}
Kurztext	Artikelnr	gew	kg	$L_{WA \text{ tot}}$		
			kg	125 Hz		
			kg	250 Hz		
U : Spannung	I_A / I_N : la/ln	Icon	500 Hz			
P_i : Leitung kW	Icon	IP	1 kHz			
I_N : Strom A	Icon	schaltpl	2 kHz			
n : Drehzahl min ⁻¹	Icon	Schalter	4 kHz			
C_{400V} : Konde μF	Icon	Reglertr	8 kHz			
t_R : tr °C	Icon	Reglerel				

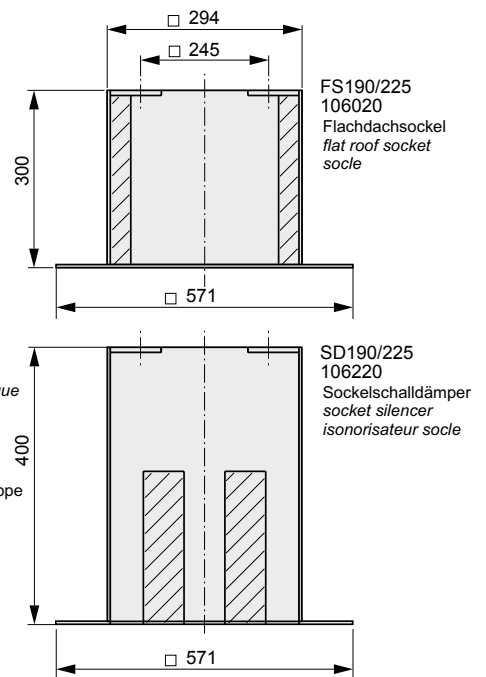
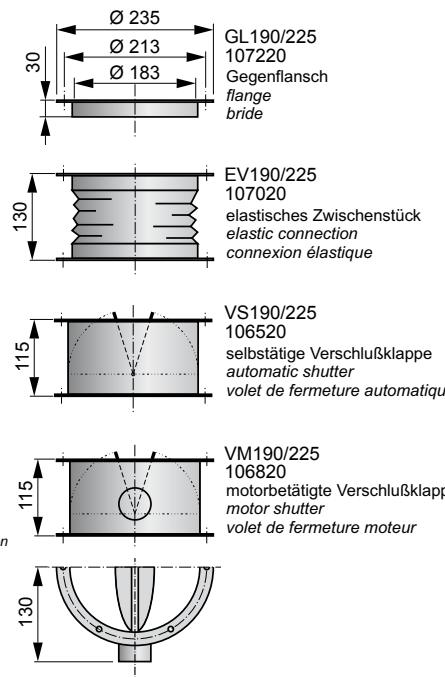
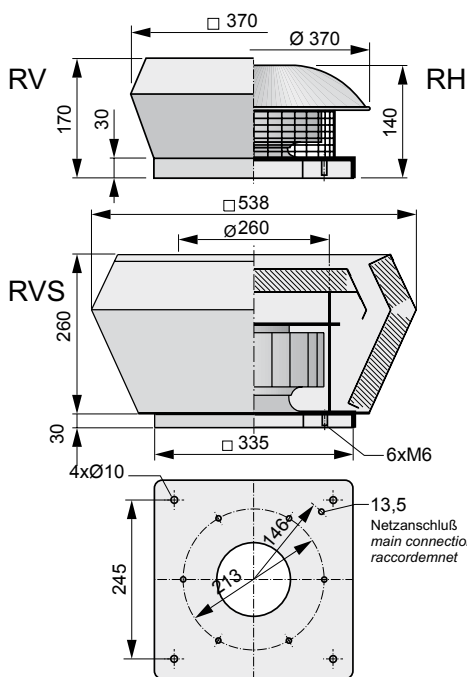

RH / RV / RVS 310K-4/4 E

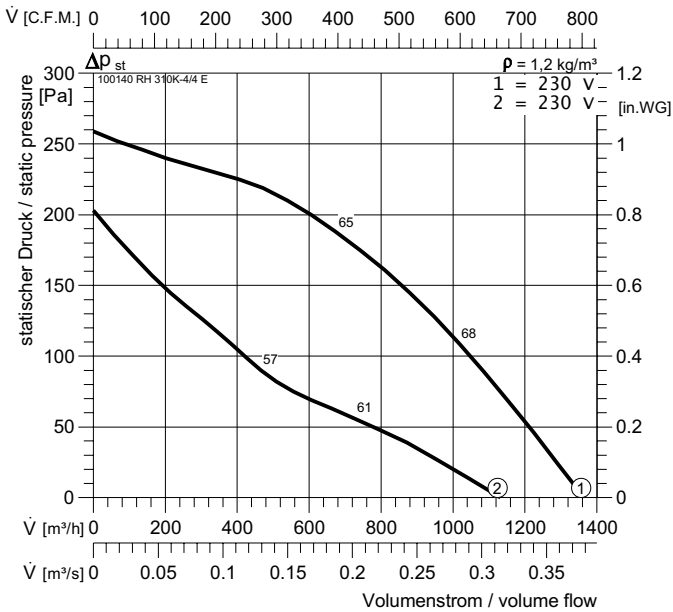

Typ	ArtNr		$L_{WA,rel}$ ΔdB	L_{WA5}	L_{WA8}
RH 310K-4/4 E	100140	12,8 kg	$L_{WA,tot}$	-2	0
RV 310K-4/4 E	102620	15,2 kg	125 Hz	-16	-20
RVS 310K-4/4 E	100145	19,4 kg	250 Hz	-10	-11
U : 230 V 50 Hz	I_A / I_N : 2		500 Hz	-10	-6
P_1 : 0,12/0,08 kW		IP 44	1 kHz	-7	-4
I_N : 0,6/0,4 A		E14	2 kHz	-8	-7
n : 1360/940 min ⁻¹		GS 1	4 kHz	-14	-13
C_{400V} : 4 μF		NE 1,5	8 kHz	-21	-19
t_r : 40 °C		RPE 02 A			

RH / RV / RVS 310K-6/6 E

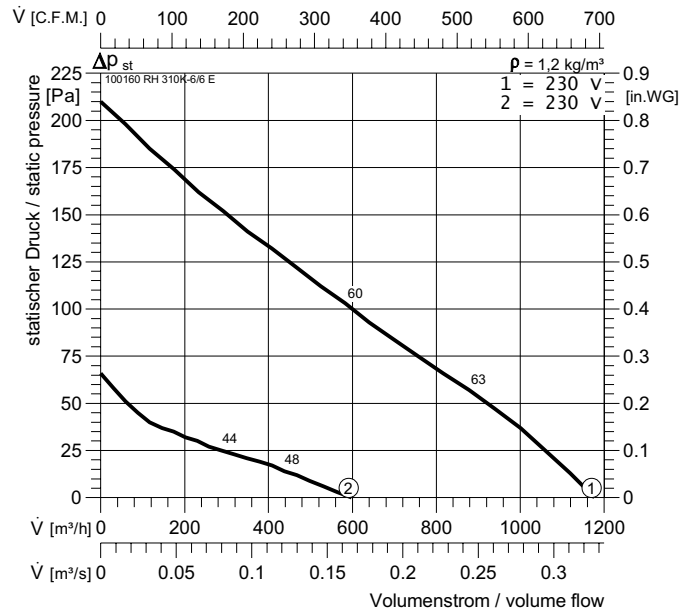

Typ	ArtNr		$L_{WA,rel}$ ΔdB	L_{WA5}	L_{WA8}
RH 310K-6/6 E	100160	11,2 kg	$L_{WA,tot}$	-2	0
RV 310K-6/6 E	102640	14,6 kg	125 Hz	-16	-20
RVS 310K-6/6 E	100165	19,4 kg	250 Hz	-10	-11
U : 230 V 50 Hz	I_A / I_N : 1,3		500 Hz	-10	-6
P_1 : 0,08/0,04 kW		IP 44	1 kHz	-7	-4
I_N : 0,35/0,16 A		E14	2 kHz	-8	-7
n : 1050/480 min ⁻¹		GS 1	4 kHz	-14	-13
C_{400V} : 1,5 μF		NE 0,5	8 kHz	-21	-19
t_r : 60 °C		RPE 02 A			

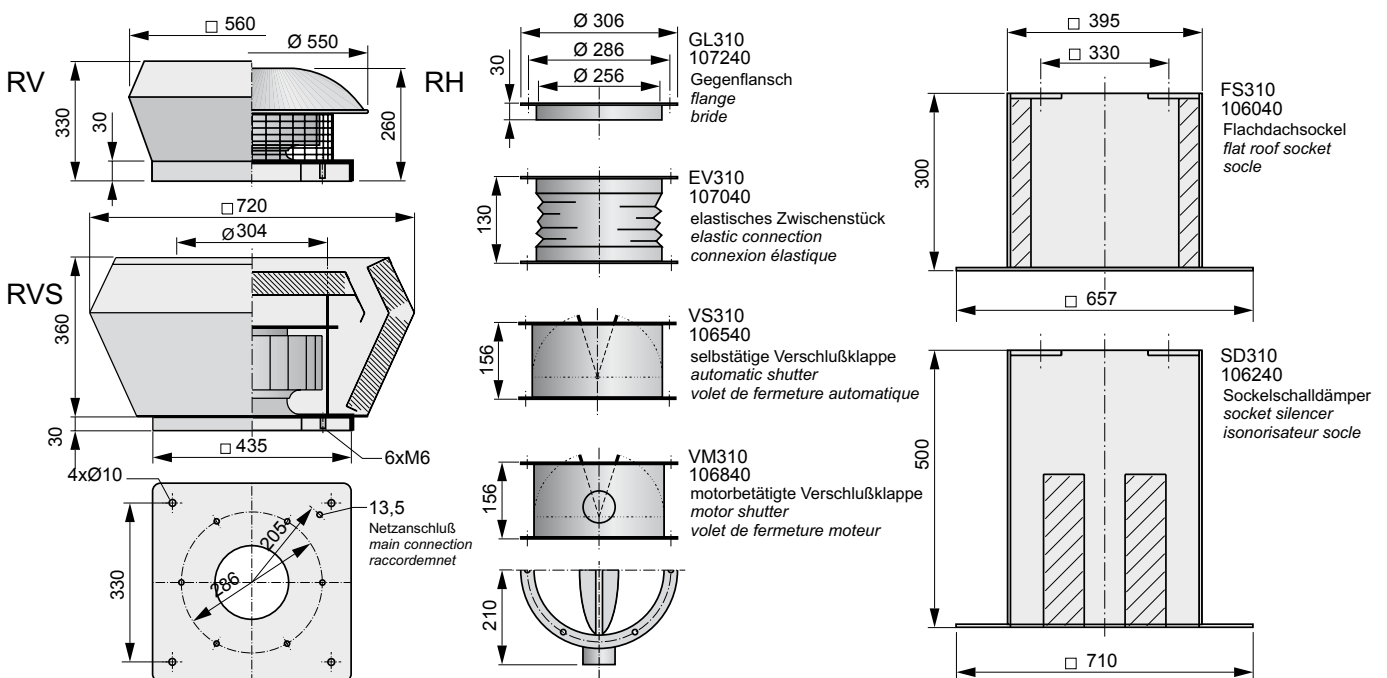



RH



RV, RVS



RH / RV / RVS 310K-4/4 D

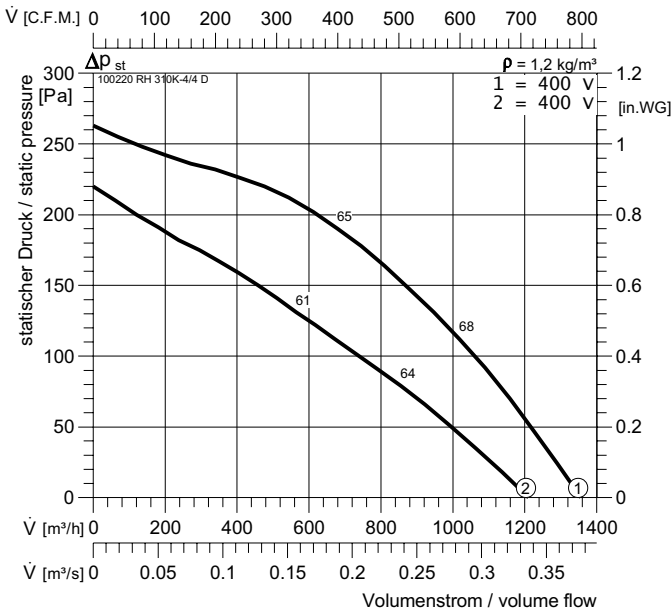

RH / RV / RVS 310K-6 D

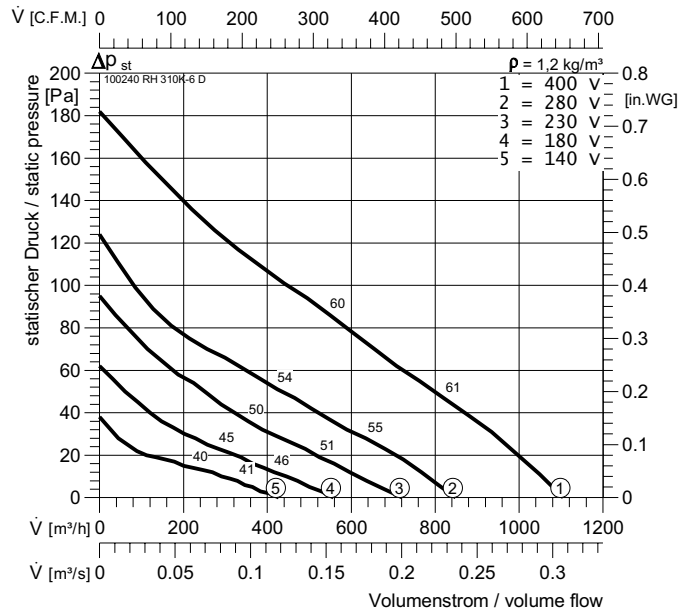

Typ	ArtNr	Icon	Weight	$L_{WA \text{ rel}}$ ΔdB	L_{WA5}	L_{WA8}
RH 310K-4/4 D	100220	12	kg	$L_{WA \text{ tot}}$ -2	-2	0
RV 310K-4/4 D	102700	13	kg	125 Hz	-16	-20
RVS 310K-4/4 D	100225	19,4	kg	250 Hz	-10	-11
U : 400 V 50 Hz	I_A / I_N : 2,1			500 Hz	-10	-6
P_i : 0,12/0,08 kW	IP 44			1 kHz	-7	-4
I_N : 0,3/0,13 A	DU3			2 kHz	-8	-7
n : 1370/1150 min ⁻¹	GS 2			4 kHz	-14	-13
C_{400V} : - μF	RTD 1,2			8 kHz	-21	-19
t_R : 55 °C	SAD 9					

Typ	ArtNr	Icon	Weight	$L_{WA \text{ rel}}$ ΔdB	L_{WA5}	L_{WA8}
RH 310K-6 D	100240	11,5	kg	$L_{WA \text{ tot}}$ -2	-2	0
RV 310K-6 D	102720	14	kg	125 Hz	-16	-20
RVS 310K-6 D	100245	14	kg	250 Hz	-10	-11
U : 400 V 50 Hz	I_A / I_N : 2,5			500 Hz	-10	-6
P_i : 0,070 kW	IP 44			1 kHz	-7	-4
I_N : 0,12 A	DD0b			2 kHz	-8	-7
n : 970 min ⁻¹	GS 2			4 kHz	-14	-13
C_{400V} : - μF	RTD 1,2			8 kHz	-21	-19
t_R : 60 °C	SAD 9					

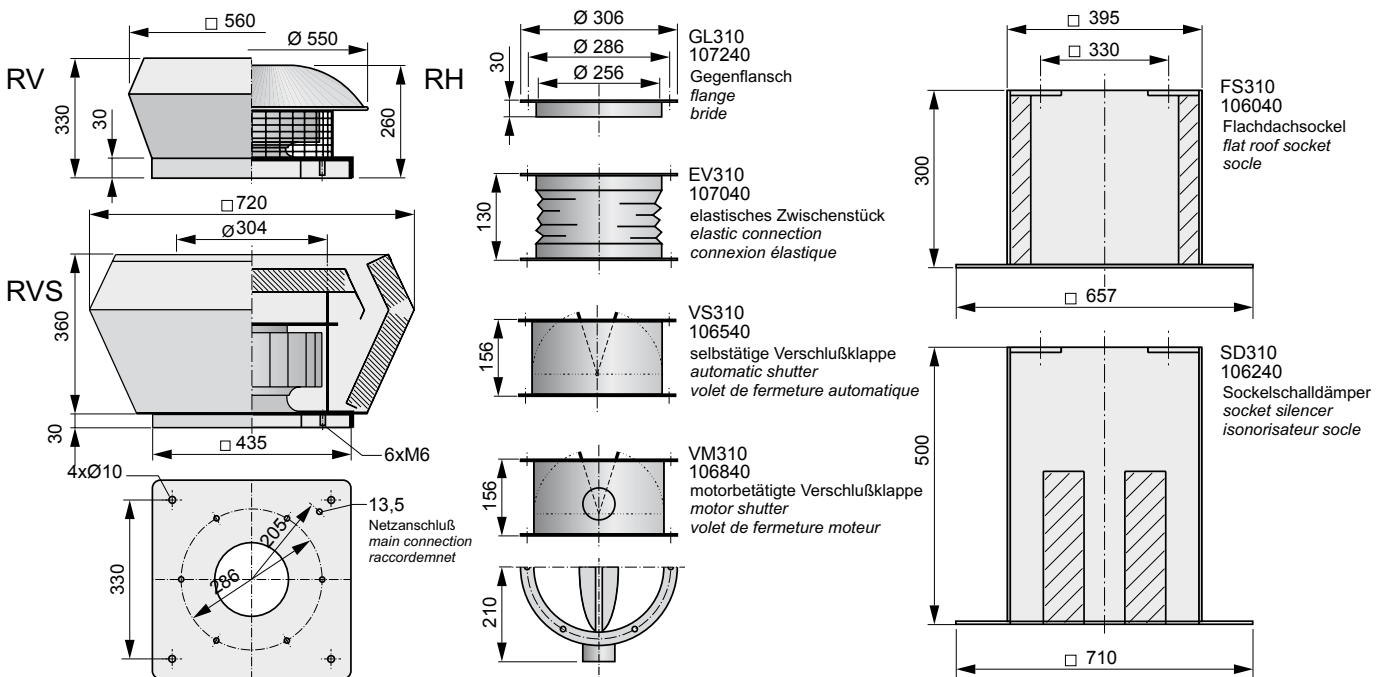

RH / RV / RVS 310L-4/4 E

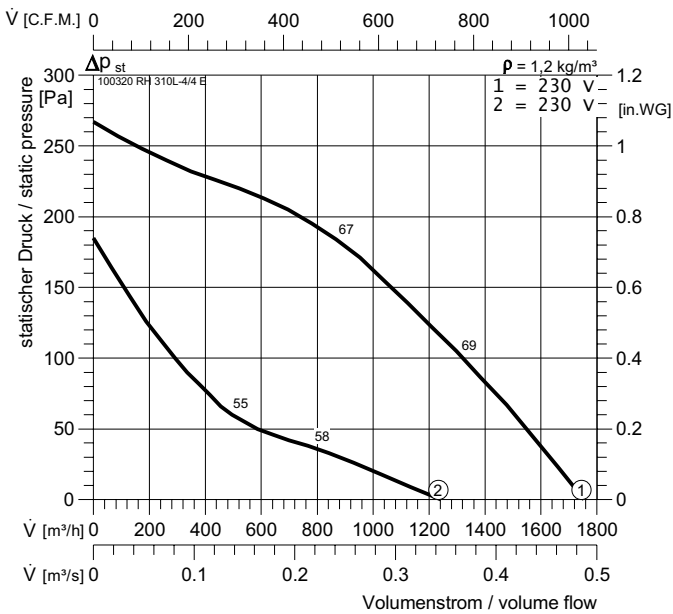

Typ	ArtNr		$L_{WA\ rel}$ ΔdB	L_{WA5}	L_{WA8}
RH 310L-4/4 E	100320	13 kg	$L_{WA\ tot}$	-2	0
RV 310L-4/4 E	102800	15,4 kg	125 Hz	-16	-20
RVS 310L-4/4 E	100325	19,5 kg	250 Hz	-10	-11
U : 230 V 50 Hz	I_A / I_N : 1,8		500 Hz	-10	-6
P_1 : 0,15/0,07 kW		IP 44	1 kHz	-7	-4
I_N : 0,66/0,46 A		E14	2 kHz	-8	-7
n : 1300/740 min ⁻¹		GS 1	4 kHz	-14	-13
C_{400V} : 4 μF		NE 1,5	8 kHz	-21	-19
t_r : 50 °C		RPE 02			

RH / RV / RVS 310L-6/6 E

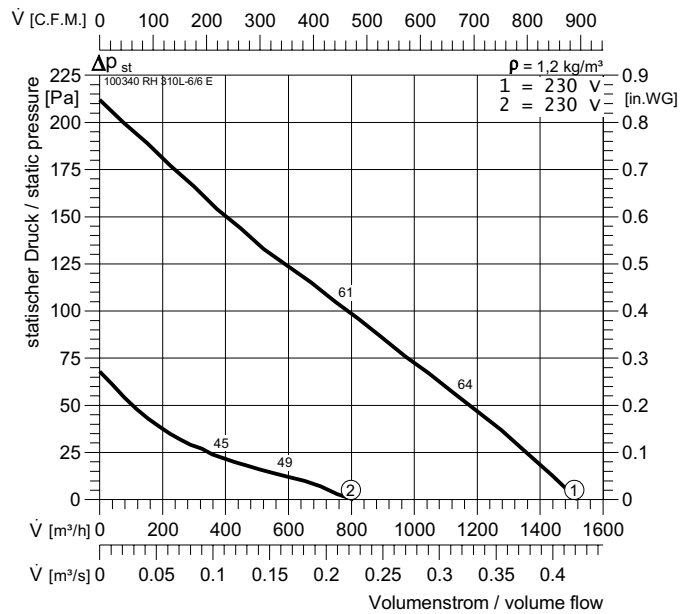

Typ	ArtNr		$L_{WA\ rel}$ ΔdB	L_{WA5}	L_{WA8}
RH 310L-6/6 E	100340	11,6 kg	$L_{WA\ tot}$	-2	0
RV 310L-6/6 E	102820	15 kg	125 Hz	-16	-20
RVS 310L-6/6 E	100345	19,4 kg	250 Hz	-10	-11
U : 230 V 50 Hz	I_A / I_N : -		500 Hz	-10	-6
P_1 : 0,1/0,055 kW		IP 44	1 kHz	-7	-4
I_N : 0,5/0,26 A		E14	2 kHz	-8	-7
n : 1020/500 min ⁻¹		GS 1	4 kHz	-14	-13
C_{400V} : 2 μF		NE 0,5	8 kHz	-21	-19
t_r : 60 °C		RPE 02 A			

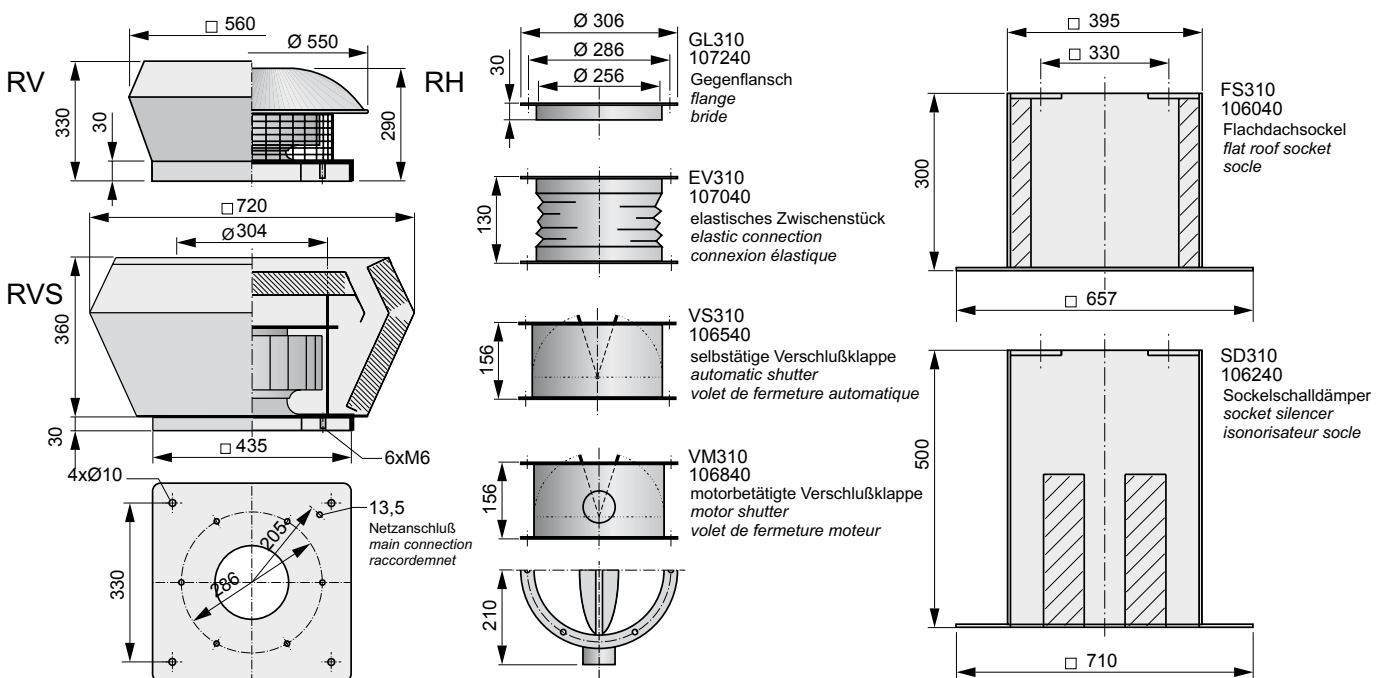

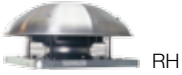

RH



RV, RVS



RH / RV / RVS 310L-4/4 D

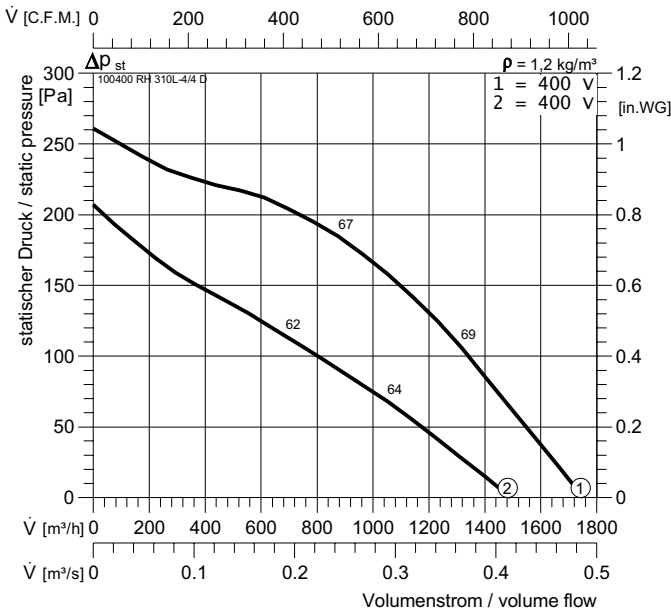

RH / RV / RVS 310L-6 D

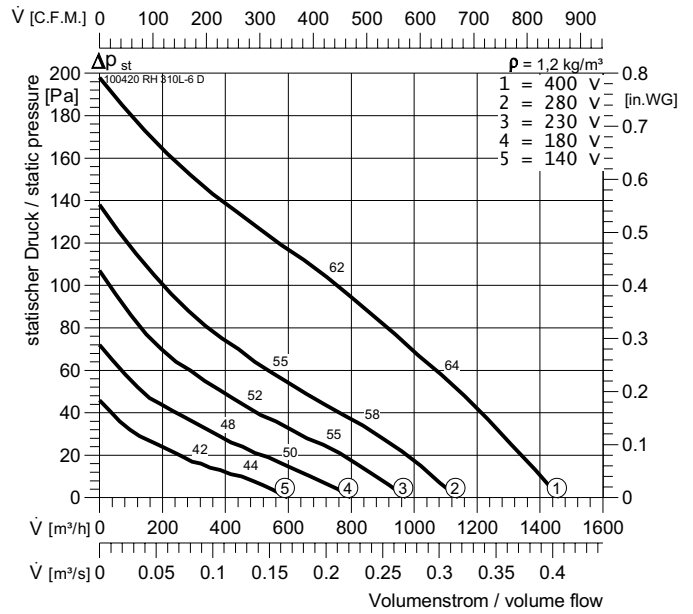

Typ	ArtNr		$L_{WA \text{ rel}}$ ΔdB	L_{WA5}	L_{WA8}
RH 310L-4/4 D	100400	12,8 kg	$L_{WA \text{ tot}}$ -2	0	
RV 310L-4/4 D	102880	13 kg	125 Hz -16	-20	
RVS 310L-4/4 D	100405	19,4 kg	250 Hz -10	-11	
U : 400 V 50 Hz	I_A / I_N : 2,3		500 Hz -10	-6	
P_i : 0,15/0,09 kW		IP 44	1 kHz -7	-4	
I_N : 0,32/0,16 A		DU3	2 kHz -8	-7	
n : 1320/1030 min ⁻¹		GS 2	4 kHz -14	-13	
C_{400V} : - μF		RTD 1,2	8 kHz -21	-19	
t_R : 50 °C		SAD 9			

Typ	ArtNr		$L_{WA \text{ rel}}$ ΔdB	L_{WA5}	L_{WA8}
RH 310L-6 D	100420	11,8 kg	$L_{WA \text{ tot}}$ -2	0	
RV 310L-6 D	102900	14 kg	125 Hz -16	-20	
RVS 310L-6 D	100425	14 kg	250 Hz -10	-11	
U : 400 V 50 Hz	I_A / I_N : 1,6		500 Hz -10	-6	
P_i : 0,09 kW		IP 44	1 kHz -7	-4	
I_N : 0,16 A		DD0b	2 kHz -8	-7	
n : 1000 min ⁻¹		GS 2	4 kHz -14	-13	
C_{400V} : - μF		RTD 1,2	8 kHz -21	-19	
t_R : 50 °C		SAD 9			

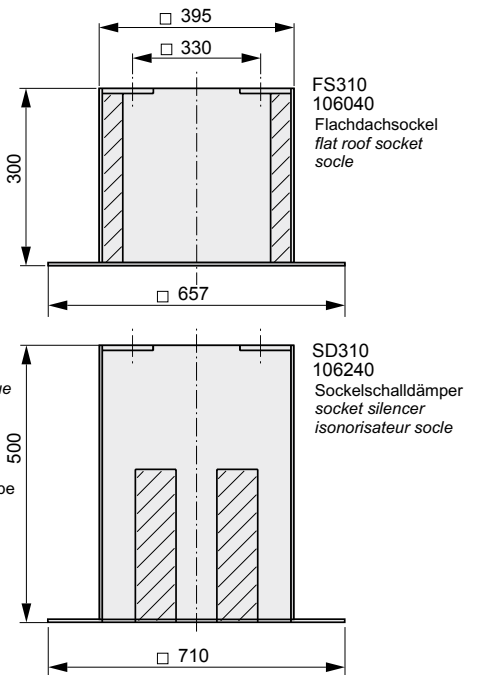
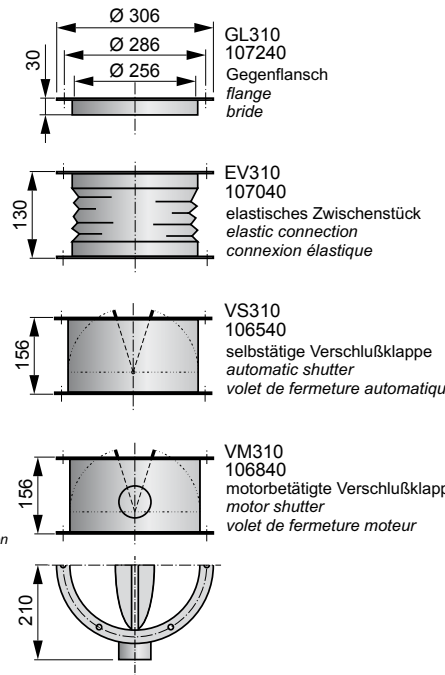
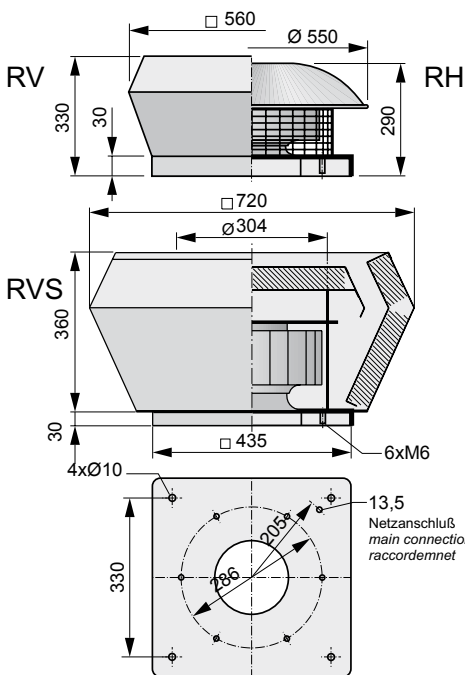

RH / RV / RVS 355-4 E

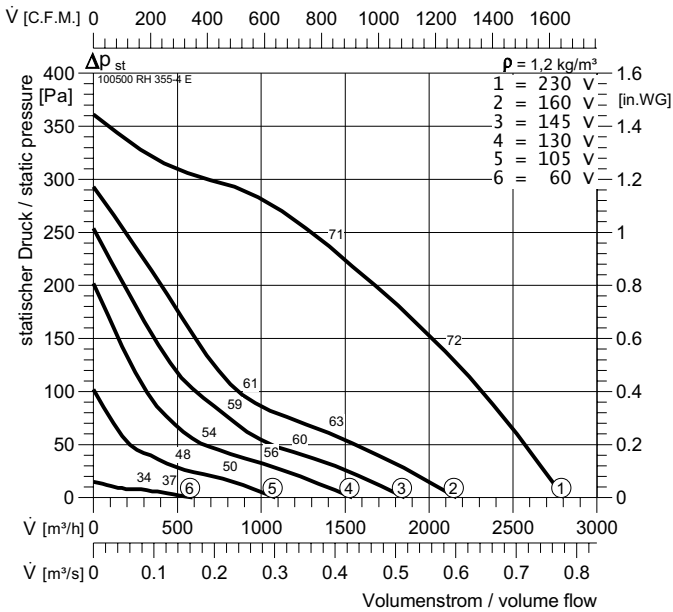

Typ	ArtNr		$L_{WA,rel}$ ΔdB	L_{WA5}	L_{WA8}
RH 355-4 E	100500	23,8 kg	$L_{WA,tot}$ -2	0	0
RV 355-4 E	102980	24,2 kg	125 Hz -16	-20	
RVS 355-4 E	100505	28 kg	250 Hz -10	-11	
U : 230 V 50 Hz	I_A / I_N : 1,8		500 Hz -10	-6	
P_1 : 0,28 kW		IP 54	1 kHz -7	-4	
I_N : 1,25 A		E13	2 kHz -8	-7	
n : 1255 min ⁻¹		GS 1	4 kHz -14	-13	
C_{400V} : 5 μF		NE 1,5	8 kHz -21	-19	
t_R : 60 °C		RPE 06			

RH / RV / RVS 355-6 E

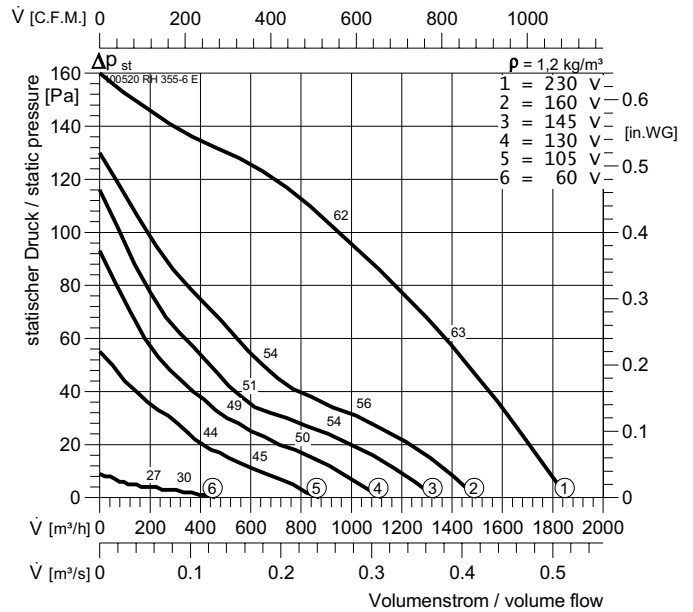

Typ	ArtNr		$L_{WA,rel}$ ΔdB	L_{WA5}	L_{WA8}
RH 355-6 E	100520	21,6 kg	$L_{WA,tot}$ -2	0	0
RV 355-6 E	103000	25,8 kg	125 Hz -16	-20	
RVS 355-6 E	100525	28 kg	250 Hz -10	-11	
U : 230 V 50 Hz	I_A / I_N : 1,3		500 Hz -10	-6	
P_1 : 0,11 kW		IP 54	1 kHz -7	-4	
I_N : 0,50 A		E13	2 kHz -8	-7	
n : 830 min ⁻¹		GS 1	4 kHz -14	-13	
C_{400V} : 2 μF		NE 0,5	8 kHz -21	-19	
t_R : 60 °C		RPE 02			

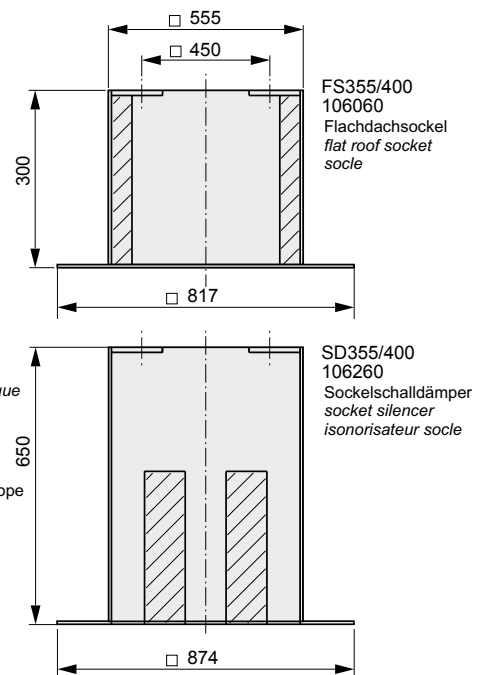
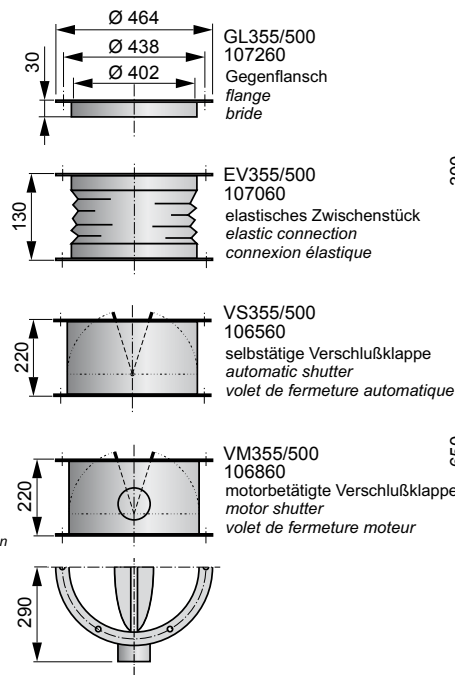
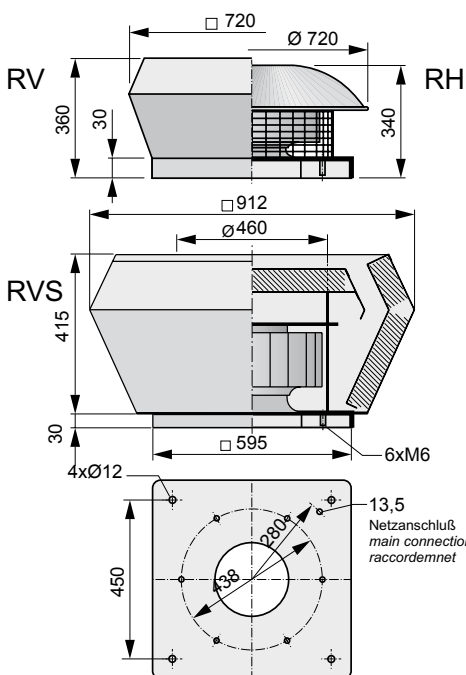

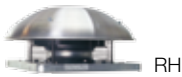

RH



RV, RVS



RH / RV / RVS 355-4/4 D

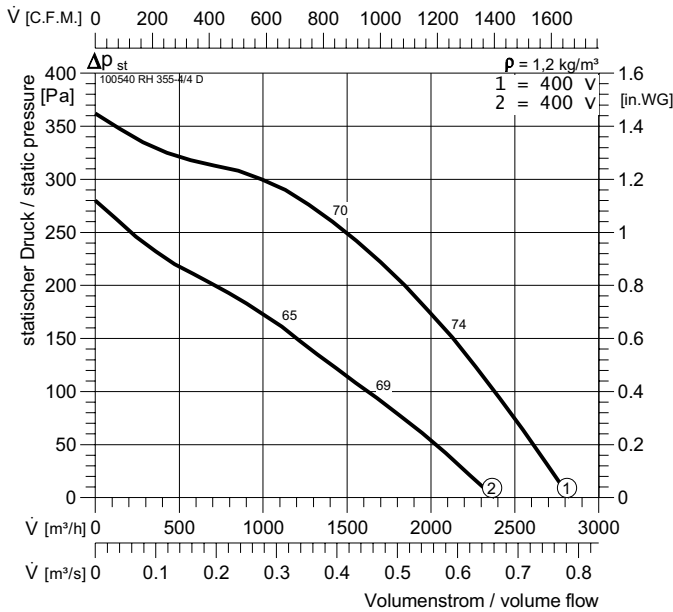

RH / RV / RVS 355-6 D

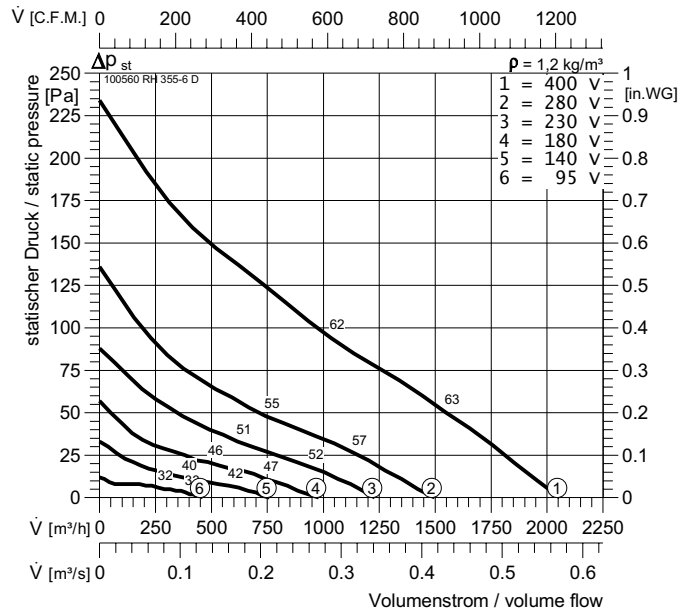

Typ	ArtNr		$L_{WA \text{ rel}}$ ΔdB	L_{WA5}	L_{WA8}
RH 355-4/4 D	100540	22,2 kg	$L_{WA \text{ tot}}$ -2	0	
RV 355-4/4 D	103020	21 kg	125 Hz -16	-20	
RVS 355-4/4 D	100545	28 kg	250 Hz -10	-11	
U : 400 V 50 Hz	I_A / I_N : 2,7	500 Hz -10	-6		
P_i : 0,27/0,18 kW		1 kHz -7	-4		
I_N : 0,55/0,3 A		2 kHz -8	-7		
n : 1310/1040 min ⁻¹		4 kHz -14	-13		
C_{400V} : - μF		8 kHz -21	-19		
t_R : 60 °C		SAD 9			

Typ	ArtNr		$L_{WA \text{ rel}}$ ΔdB	L_{WA5}	L_{WA8}
RH 355-6 D	100560	21,6 kg	$L_{WA \text{ tot}}$ -2	0	
RV 355-6 D	103040	20,4 kg	125 Hz -16	-20	
RVS 355-6 D	100565	28 kg	250 Hz -10	-11	
U : 400 V 50 Hz	I_A / I_N : -	500 Hz -10	-6		
P_i : 0,18 kW		1 kHz -7	-4		
I_N : 0,3 A		2 kHz -8	-7		
n : 1040 min ⁻¹		4 kHz -14	-13		
C_{400V} : - μF		8 kHz -21	-19		
t_R : 60 °C		SAD 9			

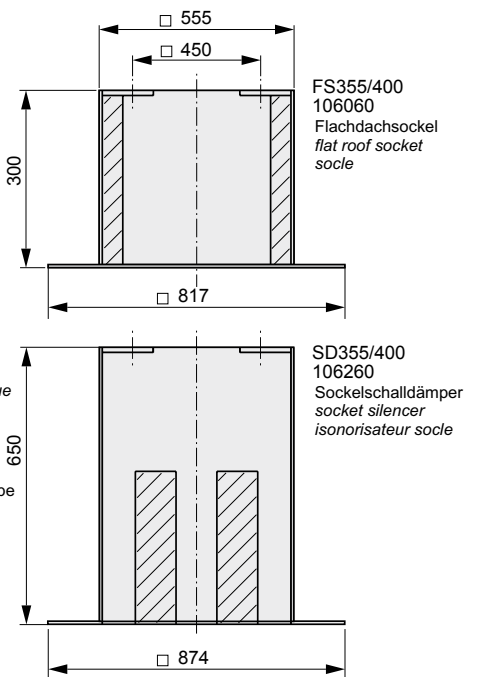
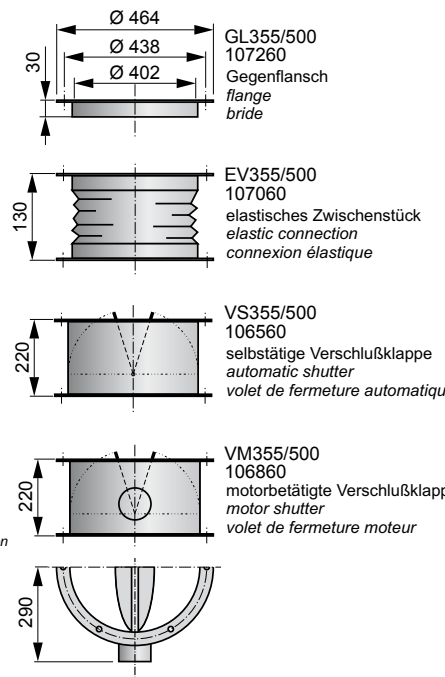
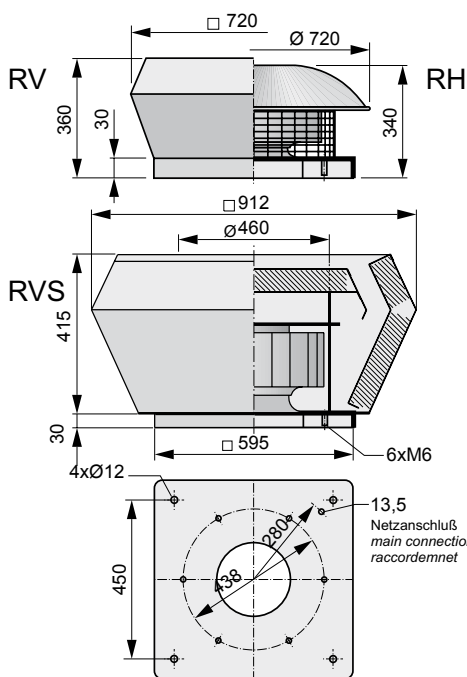

RH / RV / RVS 400-4 E

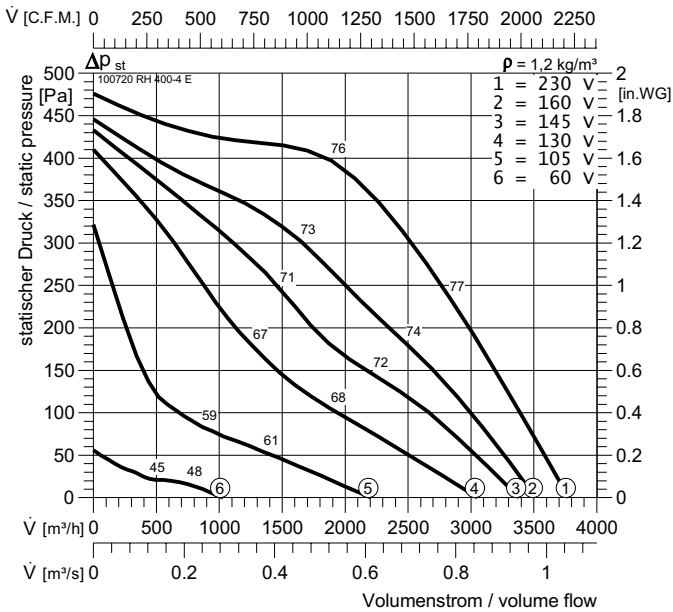

Typ	ArtNr	Icon	Weight	$L_{WA,rel}$ ΔdB	L_{WA5}	L_{WA8}
RH 400-4 E	100720		27 kg	$L_{WA,tot}$ -3	-3	0
RV 400-4 E	103200		30,8 kg	125 Hz	-18	-16
RVS 400-4 E	100725		32 kg	250 Hz	-13	-10
U : 230 V 50 Hz	I_A / I_N : 2,65		500 Hz	-12	-6	
P_1 : 0,52 kW		IP 54	1 kHz	-9	-5	
I_N : 2,43 A		E13	2 kHz	-7	-6	
n : 1385 min ⁻¹		GS 2	4 kHz	-14	-13	
C_{400V} : 12 μF		NE 3,2	8 kHz	-21	-22	
t_R : 45 °C		RPE 06				

RH / RV / RVS 400-6 E

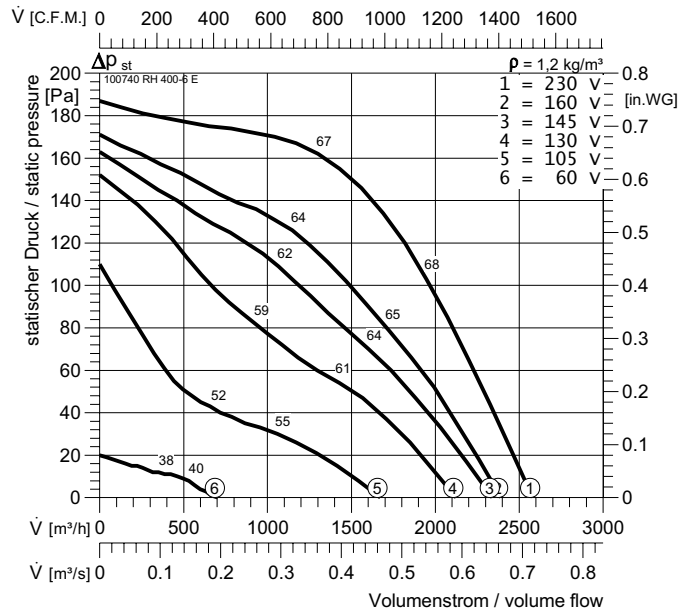

Typ	ArtNr	Icon	Weight	$L_{WA,rel}$ ΔdB	L_{WA5}	L_{WA8}
RH 400-6 E	100740		22 kg	$L_{WA,tot}$ -3	-3	0
RV 400-6 E	103220		24,8 kg	125 Hz	-18	-16
RVS 400-6 E	100745		35 kg	250 Hz	-13	-10
U : 230 V 50 Hz	I_A / I_N : 2,5		500 Hz	-12	-6	
P_1 : 0,19 kW		IP 54	1 kHz	-9	-5	
I_N : 0,88 A		E13	2 kHz	-7	-6	
n : 920 min ⁻¹		GS 2	4 kHz	-14	-13	
C_{400V} : 4 μF		NE 1,5	8 kHz	-21	-22	
t_R : 60 °C		RPE 02				

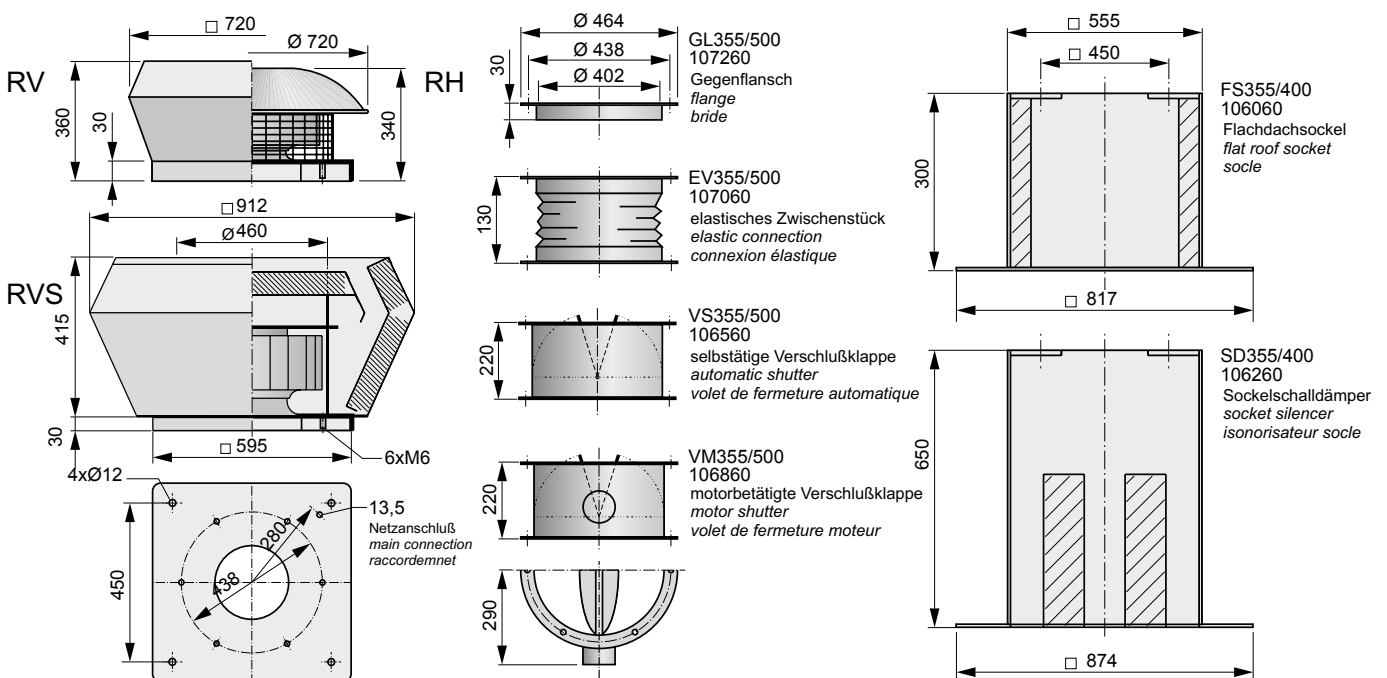



RH



RV, RVS



RH / RV / RVS 400-4/4 D

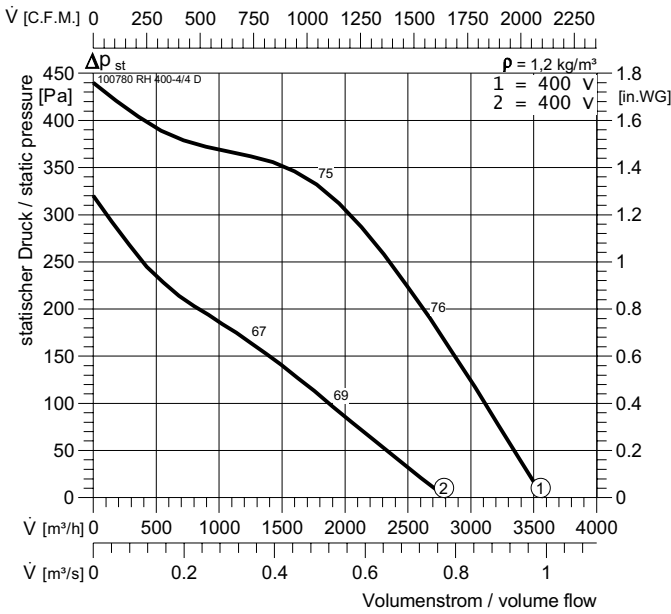

RH / RV / RVS 400-6/6 D

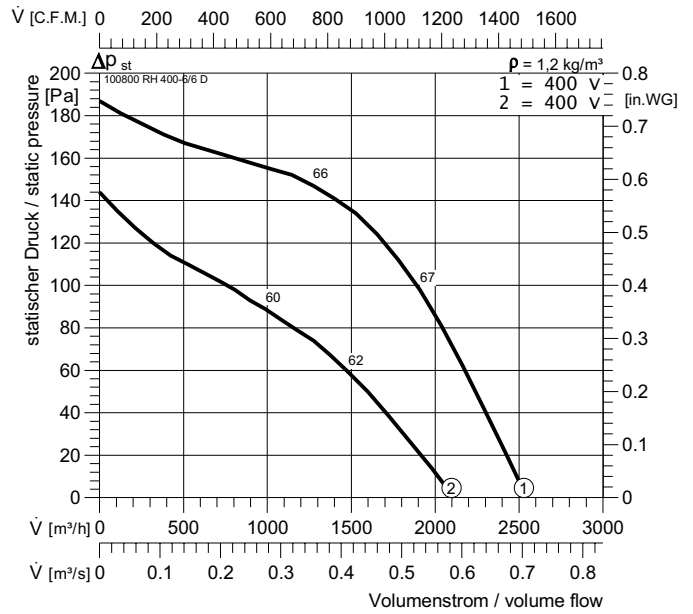

Typ	ArtNr		$L_{WA\ rel}$ ΔdB	L_{WA5}	L_{WA8}
RH 400-4/4 D	100780	26,2 kg	$L_{WA\ tot}$ -3	0	
RV 400-4/4 D	103260	29,2 kg	125 Hz -18	-16	
RVS 400-4/4 D	100785	32 kg	250 Hz -13	-10	
U : 400 V 50 Hz	I_A / I_N : 2,6	500 Hz -12	-6		
P_i : 0,43/0,27 kW		1 kHz -9	-5		
I_N : 0,74/0,45 A		2 kHz -7	-6		
n : 1275/895 min ⁻¹		4 kHz -14	-13		
C_{400V} : - μF		8 kHz -21	-22		
t_R : 40 °C					

Typ	ArtNr		$L_{WA\ rel}$ ΔdB	L_{WA5}	L_{WA8}
RH 400-6/6 D	100800	21 kg	$L_{WA\ tot}$ -3	0	
RV 400-6/6 D	103280	24,7 kg	125 Hz -18	-16	
RVS 400-6/6 D	100805	32 kg	250 Hz -13	-10	
U : 400 V 50 Hz	I_A / I_N : 2,8	500 Hz -12	-6		
P_i : 0,15/0,1 kW		1 kHz -9	-5		
I_N : 0,29/0,16 A		2 kHz -7	-6		
n : 880/680 min ⁻¹		4 kHz -14	-13		
C_{400V} : - μF		8 kHz -21	-22		
t_R : 60 °C					

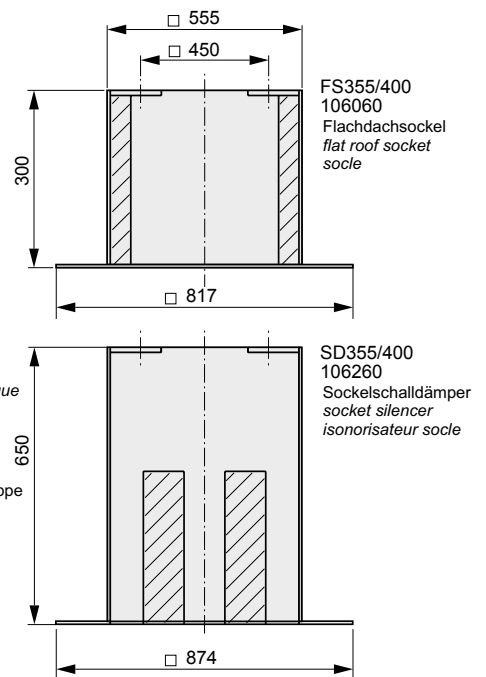
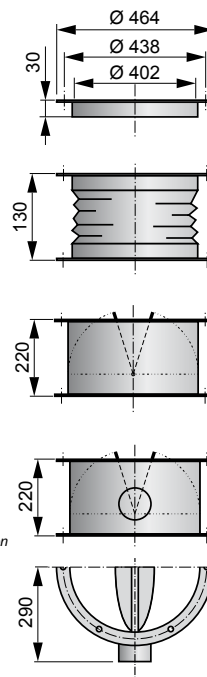
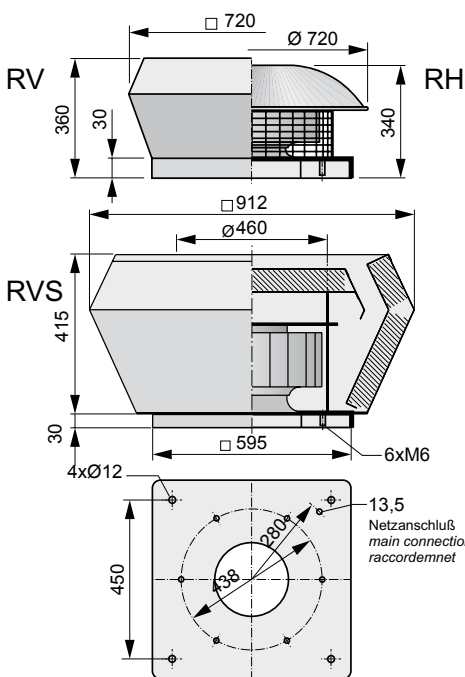

RH / RV / RVS 450-4 E

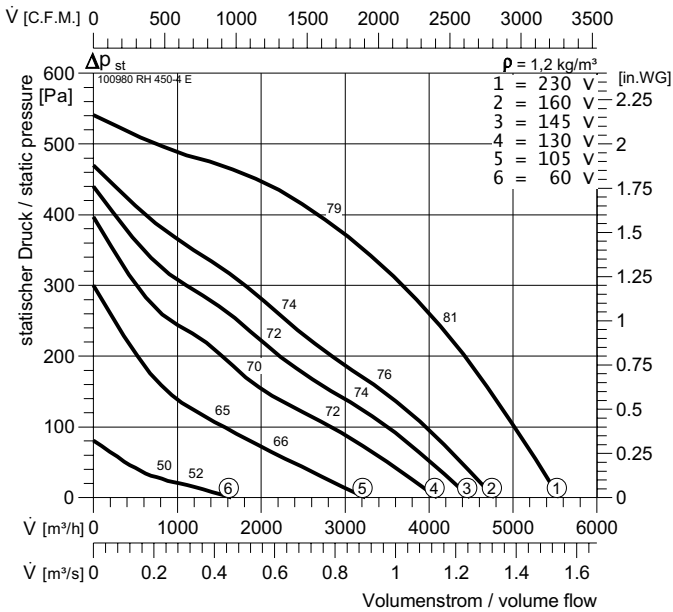

RH / RV / RVS 450-6 E

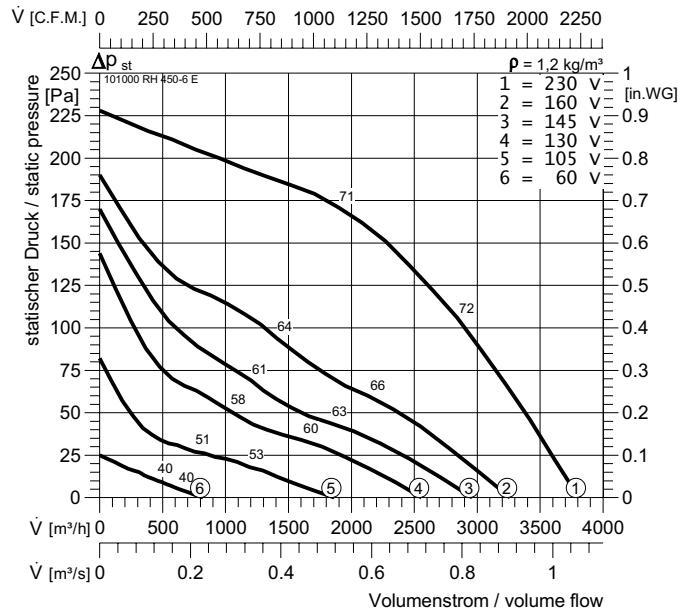

Typ	ArtNr	■	$L_{WA,rel}$ ΔdB	L_{WA5}	L_{WA8}
RH 450-4 E	100980	48 kg	$L_{WA,tot}$	-3	0
RV 450-4 E	103460	33,2 kg	125 Hz	-18	-16
RVS 450-4 E	100985	56 kg	250 Hz	-13	-10
U : 230 V 50 Hz	I_A / I_N : 2,0	500 Hz	-12	-6	
P_1 : 0,8 kW	⚠ IP 54	1 kHz	-9	-5	
I_N : 3,74 A	★ E13	2 kHz	-7	-6	
n : 1240 min ⁻¹	⏴ GS 2	4 kHz	-14	-13	
C_{400V} : 16 μF	■ NE 5	8 kHz	-21	-22	
t_R : 50 °C	⚡ RPE 09				

Typ	ArtNr	■	$L_{WA,rel}$ ΔdB	L_{WA5}	L_{WA8}
RH 450-6 E	101000	40 kg	$L_{WA,tot}$	-3	0
RV 450-6 E	103480	26 kg	125 Hz	-18	-16
RVS 450-6 E	101005	56 kg	250 Hz	-13	-10
U : 230 V 50 Hz	I_A / I_N : 1,8	500 Hz	-12	-6	
P_1 : 0,27 kW	⚠ IP 54	1 kHz	-9	-5	
I_N : 1,2 A	★ E13	2 kHz	-7	-6	
n : 860 min ⁻¹	⏴ GS 2	4 kHz	-14	-13	
C_{400V} : 5 μF	■ NE 1,5	8 kHz	-21	-22	
t_R : 50 °C	⚡ RPE 06				

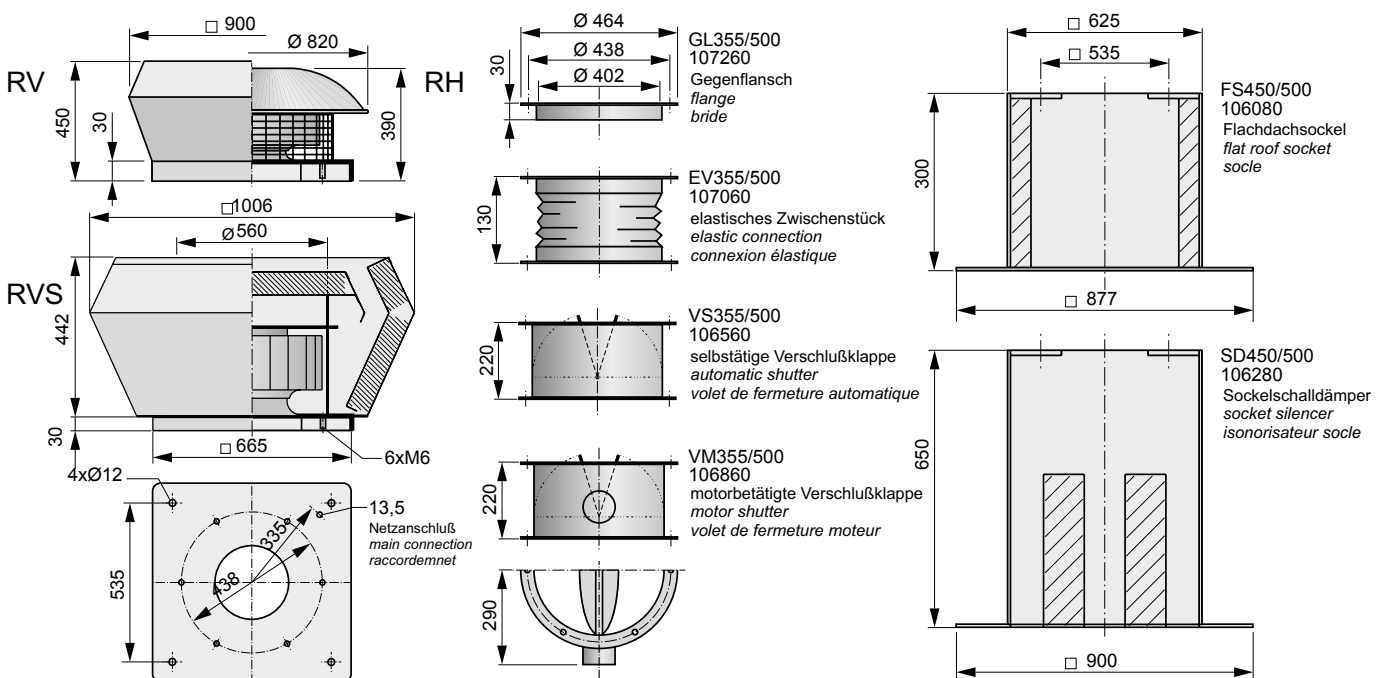



RH



RV, RVS



RH / RV / RVS 450-4/4 D

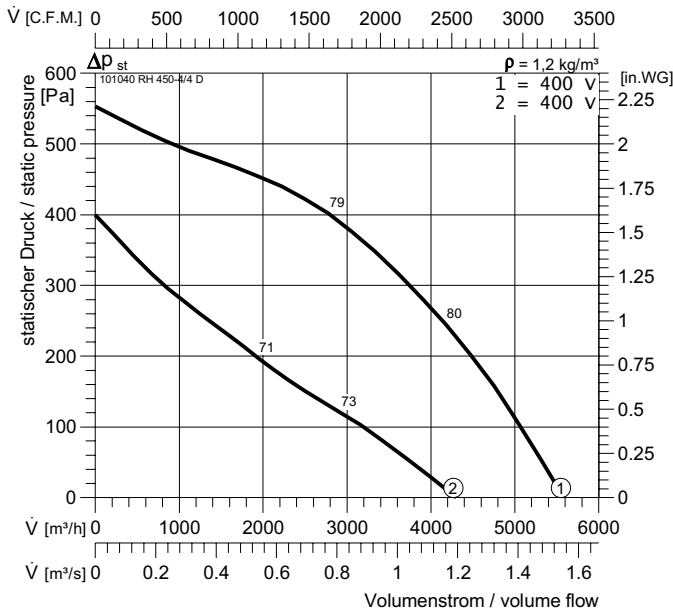

RH / RV / RVS 450-6/6 D

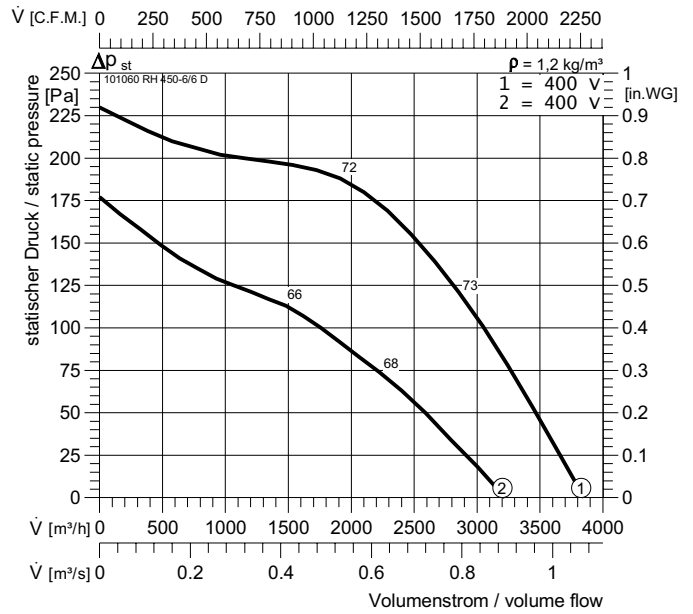

Typ	ArtNr	Icon	Weight	$L_{WA\ rel}$ ΔdB	L_{WA5}	L_{WA8}
RH 450-4/4 D	101040		48,4 kg	$L_{WA\ tot}$ -3	-3	0
RV 450-4/4 D	103520		33 kg	125 Hz	-18	-16
RVS 450-4/4 D	101045		56 kg	250 Hz	-13	-10
U : 400 V 50 Hz	I_A / I_N : 2,4		500 Hz	-12	-6	
P_i : 0,74/0,39 kW		IP 54	1 kHz	-9	-5	
I_N : 1,46/0,75 A		DU3	2 kHz	-7	-6	
n : 1240/855 min ⁻¹		GS 2	4 kHz	-14	-13	
C_{400v} : - μF		RTD 2,5	8 kHz	-21	-22	
t_R : 40 °C		SAD 9				

Typ	ArtNr	Icon	Weight	$L_{WA\ rel}$ ΔdB	L_{WA5}	L_{WA8}
RH 450-6/6 D	101060		26 kg	$L_{WA\ tot}$ -3	-3	0
RV 450-6/6 D	103540		26 kg	125 Hz	-18	-16
RVS 450-6/6 D	101065		56 kg	250 Hz	-13	-10
U : 400 V 50 Hz	I_A / I_N : 2,9		500 Hz	-12	-6	
P_i : 0,27/0,18 kW		IP 54	1 kHz	-9	-5	
I_N : 0,56/0,31 A		DU3	2 kHz	-7	-6	
n : 895/710 min ⁻¹		GS 2	4 kHz	-14	-13	
C_{400v} : - μF		RTD 1,2	8 kHz	-21	-22	
t_R : 60 °C		SAD 9				

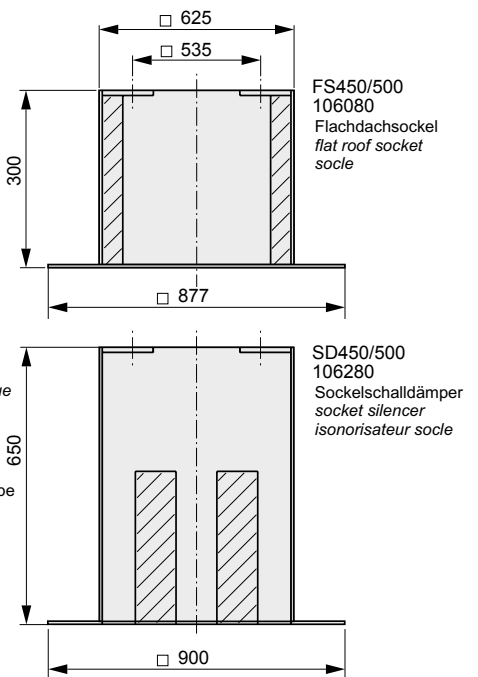
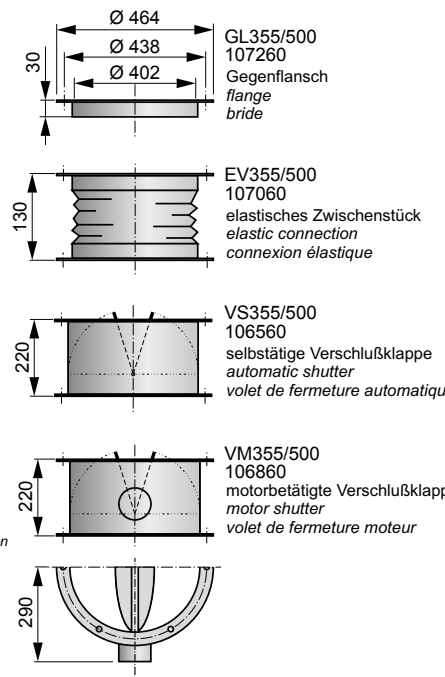
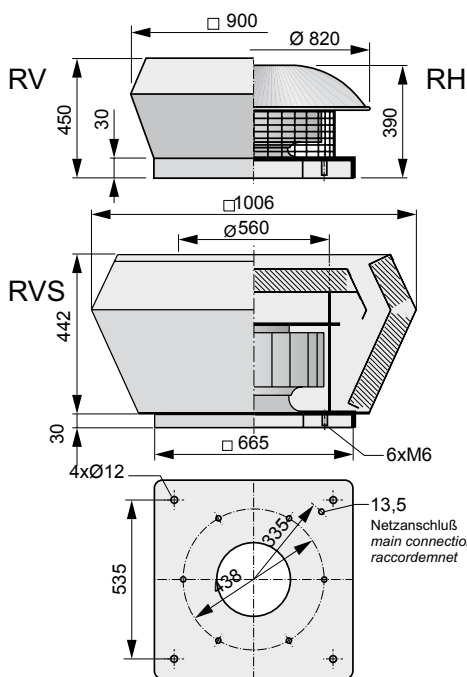

RH / RV / RVS 450L-4 E

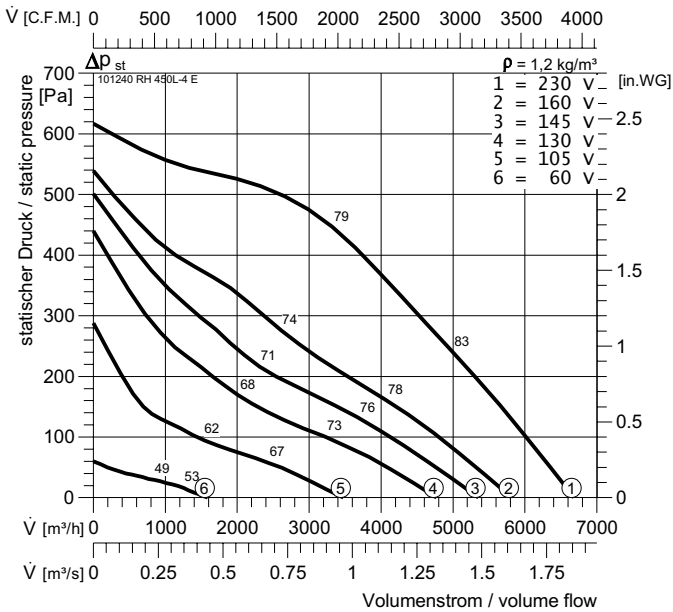

Typ	ArtNr	Gewicht	$L_{WA,rel}$ ΔdB	L_{WA5}	L_{WA8}
RH 450L-4 E	101240	34,8 kg	$L_{WA,tot}$	-3	0
RV 450L-4 E	103720	39,4 kg	125 Hz	-18	-16
RVS 450L-4 E	101245	56 kg	250 Hz	-13	-10
U : 230 V 50 Hz	I_A / I_N : 2,1	500 Hz	-12	-6	
P_1 : 1,1 kW	IP 54	1 kHz	-9	-5	
I_N : 5,0 A	E13	2 kHz	-7	-6	
n : 1310 min ⁻¹	GS 2	4 kHz	-14	-13	
C_{400V} : 25 μF	NE 5	8 kHz	-21	-22	
t_r : 50 °C	RPE 09				

RH / RV / RVS 450L-6 E

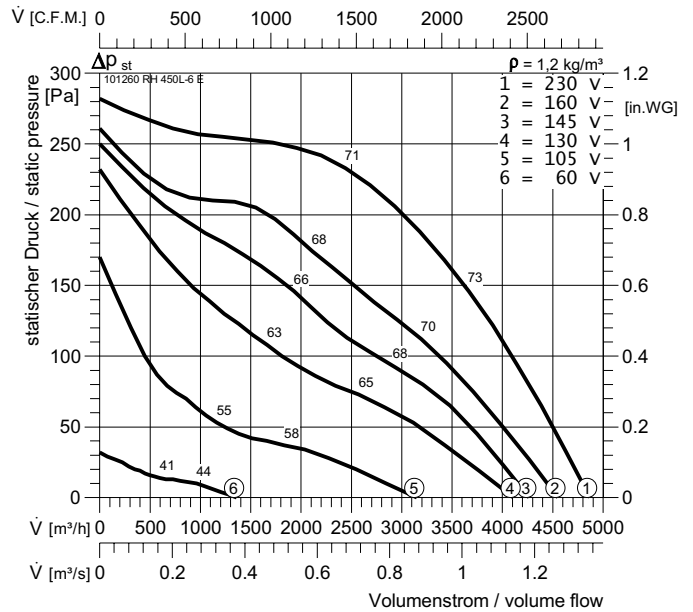

Typ	ArtNr	Gewicht	$L_{WA,rel}$ ΔdB	L_{WA5}	L_{WA8}
RH 450L-6 E	101260	27,1 kg	$L_{WA,tot}$	-3	0
RV 450L-6 E	103740	45 kg	125 Hz	-18	-16
RVS 450L-6 E	101265	56 kg	250 Hz	-13	-10
U : 230 V 50 Hz	I_A / I_N : 2,4	500 Hz	-12	-6	
P_1 : 0,43 kW	IP 54	1 kHz	-9	-5	
I_N : 2,0 A	E13	2 kHz	-7	-6	
n : 920 min ⁻¹	GS 2	4 kHz	-14	-13	
C_{400V} : 10 μF	NE 3,2	8 kHz	-21	-22	
t_r : 40 °C	RPE 06				

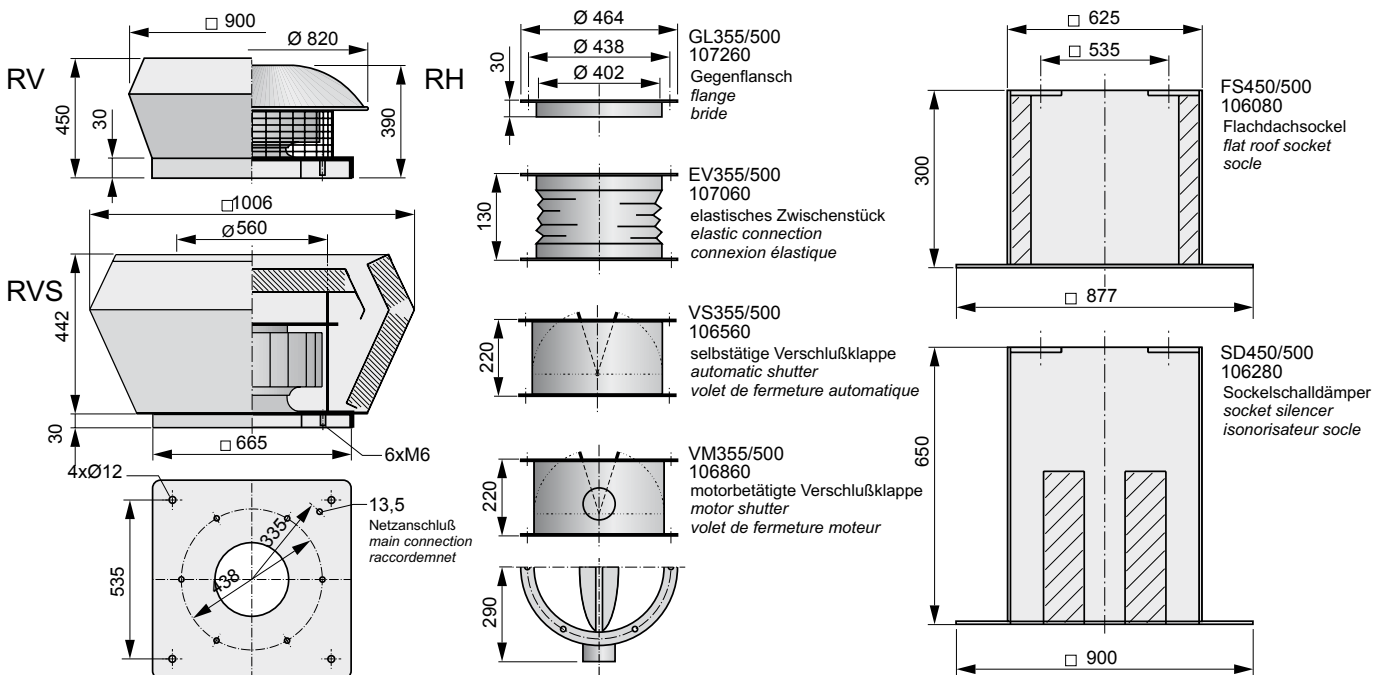



RH



RV, RVS



RH / RV / RVS 450L-4/4 D

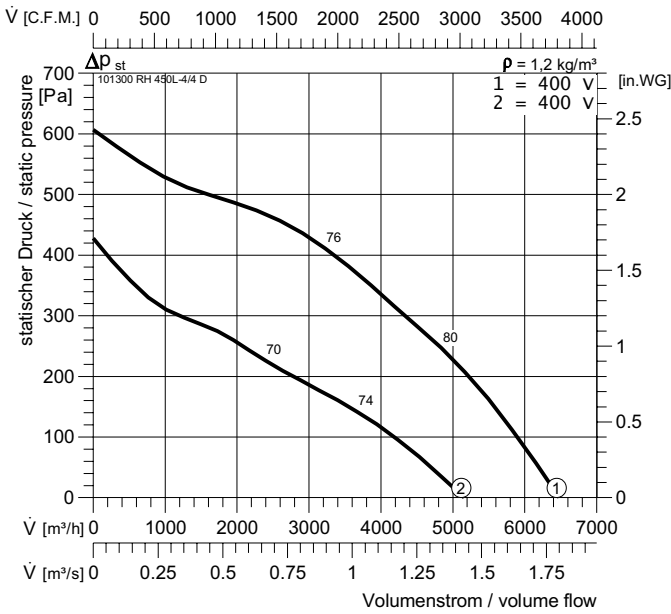

RH / RV / RVS 450L-6/6 D

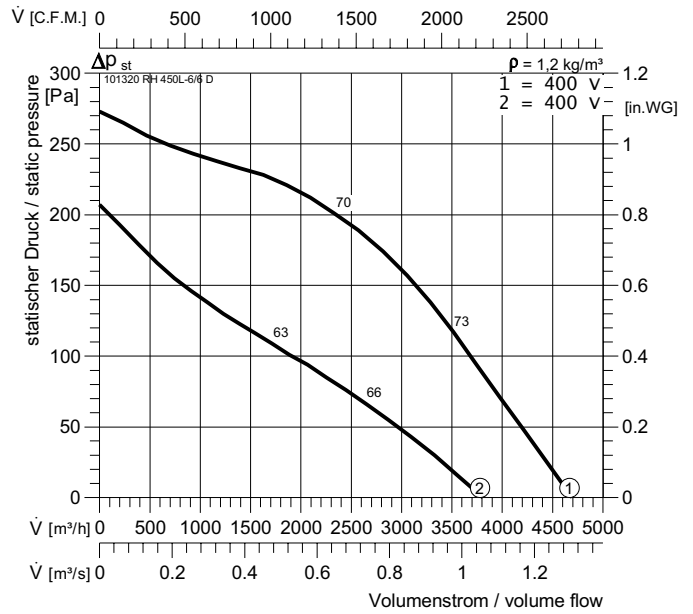

Typ	ArtNr		$L_{WA\ rel}$ ΔdB	L_{WA5}	L_{WA8}
RH 450L-4/4 D	101300	30,5 kg	$L_{WA\ tot}$ -3	-3	0
RV 450L-4/4 D	103780	56,8 kg	125 Hz	-18	-16
RVS 450L-4/4 D	101305	56 kg	250 Hz	-13	-10
U : 400 V 50 Hz	I_A / I_N : 2,6		500 Hz	-12	-6
P_i : 0,9/0,5 kW		IP 54	1 kHz	-9	-5
I_N : 1,78/0,86 A		DU3	2 kHz	-7	-6
n : 1185/885 min ⁻¹		GS 2	4 kHz	-14	-13
C_{400V} : - μF		RTD 2,5	8 kHz	-21	-22
t_R : 40 °C		SAD 9			

Typ	ArtNr		$L_{WA\ rel}$ ΔdB	L_{WA5}	L_{WA8}
RH 450L-6/6 D	101320	41 kg	$L_{WA\ tot}$ -3	-3	0
RV 450L-6/6 D	103800	41 kg	125 Hz	-18	-16
RVS 450L-6/6 D	101325	56 kg	250 Hz	-13	-10
U : 400 V 50 Hz	I_A / I_N : 2,7		500 Hz	-12	-6
P_i : 0,35/0,22 kW		IP 54	1 kHz	-9	-5
I_N : 0,64/0,35 A		DU3	2 kHz	-7	-6
n : 855/620 min ⁻¹		GS 2	4 kHz	-14	-13
C_{400V} : - μF		RTD 1,2	8 kHz	-21	-22
t_R : 60 °C		SAD 9			

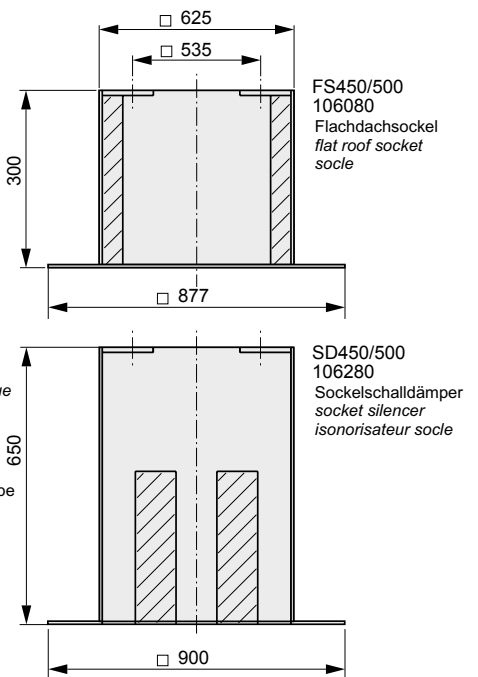
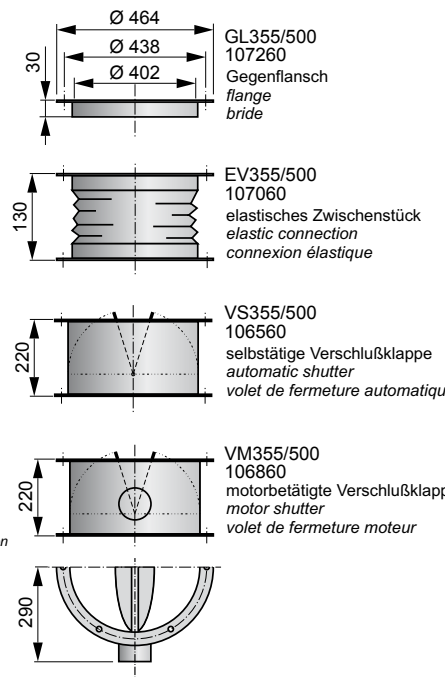
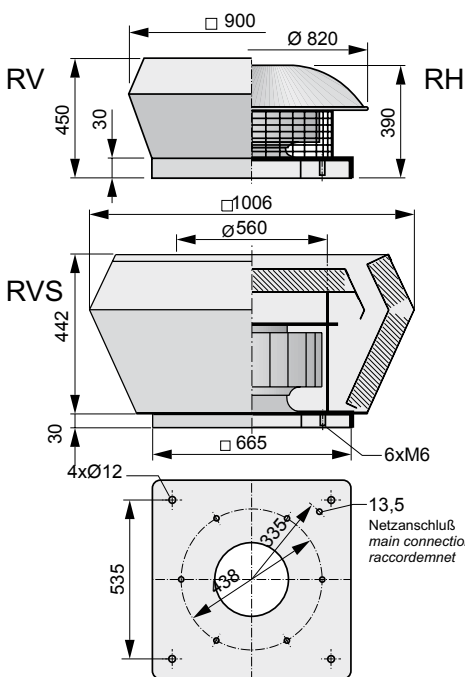

RH / RV / RVS 500-6 E

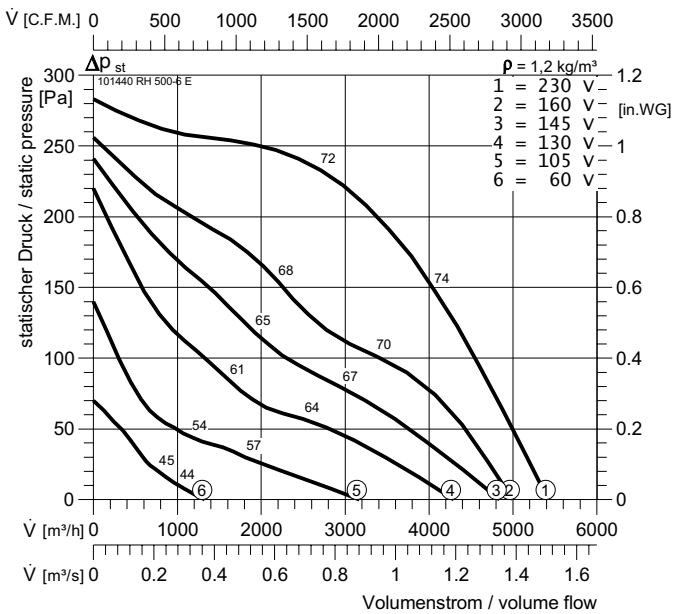

Typ	ArtNr	■	kg	$L_{WA,rel}$ ΔdB	L_{WA5}	L_{WA8}
RH 500-6 E	101440	27	kg	$L_{WA,tot}$ -3	0	
RV 500-6 E	103920	36	kg	125 Hz -17	-16	
RVS 500-6 E	101445	68	kg	250 Hz -11	-8	
U : 230 V 50 Hz	I_A / I_N : 2,1			500 Hz -11	-6	
P_1 : 0,49 kW	▲	IP 54		1 kHz -8	-5	
I_N : 2,2 A	★	E13		2 kHz -9	-8	
n : 900 min ⁻¹	□	GS 2		4 kHz -15	-14	
C_{400V} : 10 μF	■	NE 3,2		8 kHz -21	-23	
t_R : 40 °C	▽	RPE 06				

RH / RV / RVS 500-4/4 D

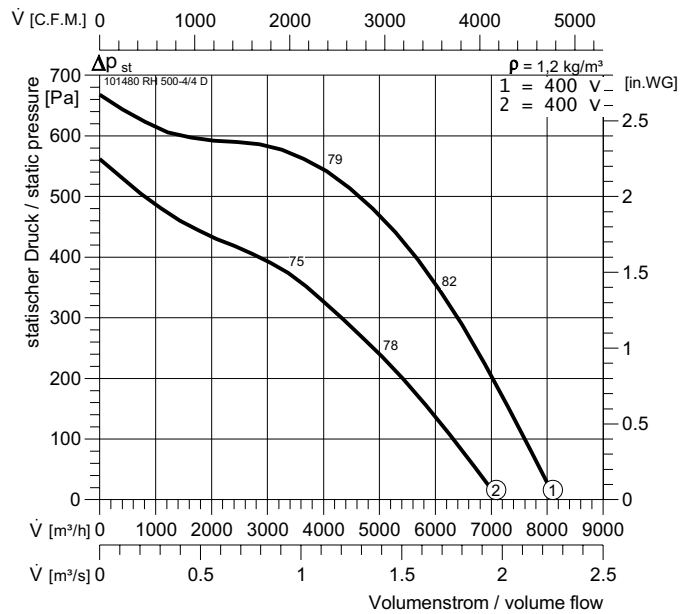

Typ	ArtNr	■	kg	$L_{WA,rel}$ ΔdB	L_{WA5}	L_{WA8}
RH 500-4/4 D	101480	46	kg	$L_{WA,tot}$ -3	0	
RV 500-4/4 D	103960	51	kg	125 Hz -17	-16	
RVS 500-4/4 D	101485	51	kg	250 Hz -11	-8	
U : 400 V 50 Hz	I_A / I_N : 3,9			500 Hz -11	-6	
P_1 : 1,35/0,97 kW	▲	IP 54		1 kHz -8	-5	
I_N : 2,6/1,6 A	★	DU3		2 kHz -9	-8	
n : 1360/1130 min ⁻¹	□	GS 2		4 kHz -15	-14	
C_{400V} : - μF	■	RTD 3		8 kHz -21	-23	
t_R : 50 °C	▽	SAD 9				

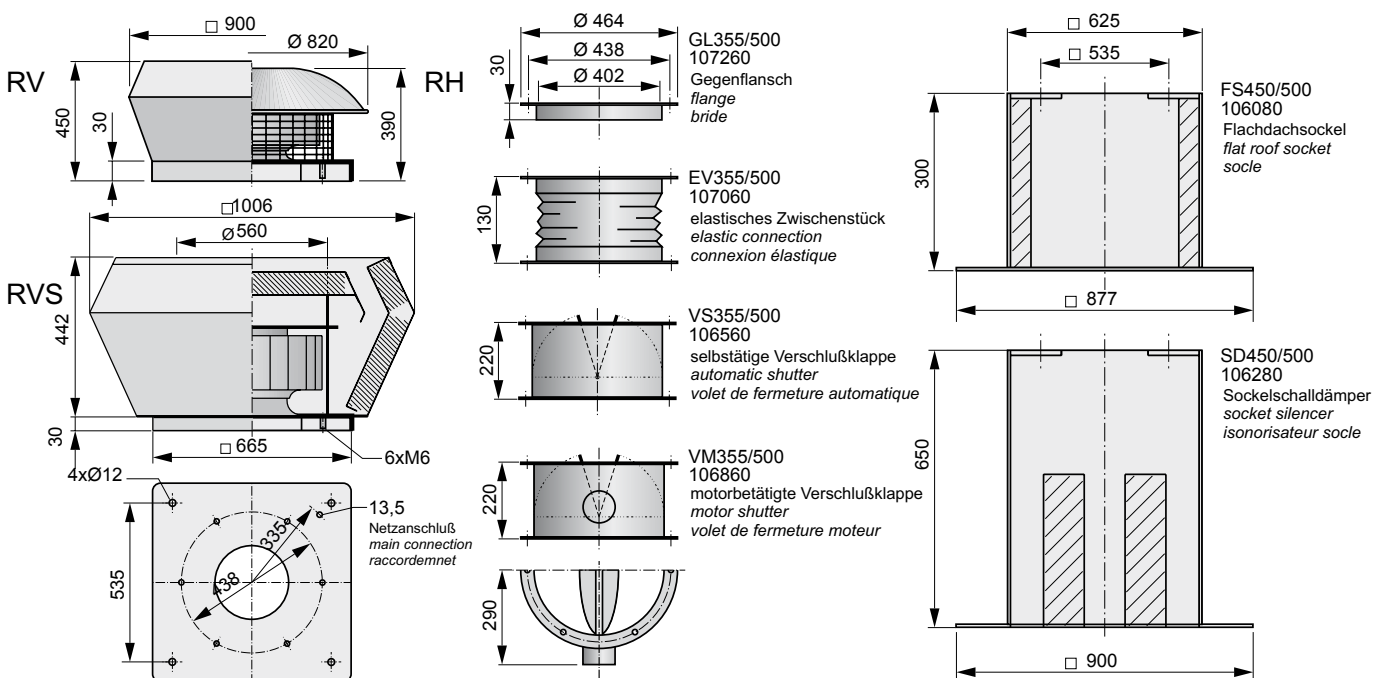



RH



RV, RVS

RH / RV / RVS 500-6/6 D

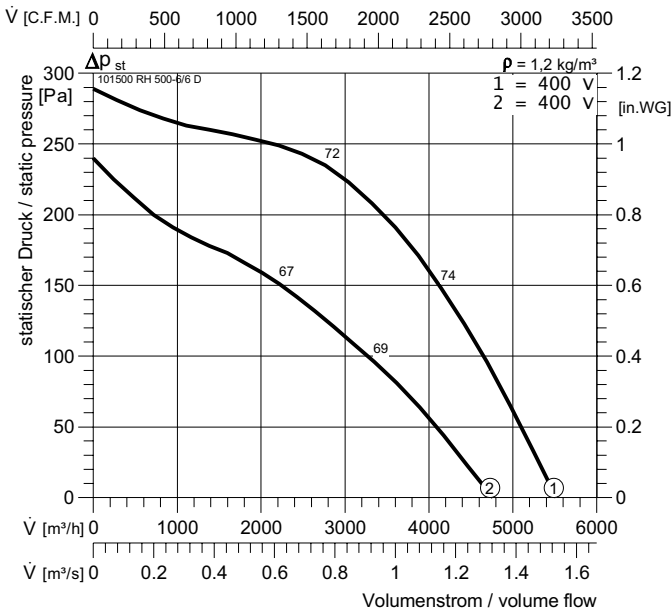

Kopfzeile

Typ	ArtNr		$L_{WA\ rel}$ ΔdB	L_{WA5}	L_{WA8}
RH 500-6/6 D	101500	42 kg	$L_{WA\ tot}$	-3	0
RV 500-6/6 D	103980	42 kg	125 Hz	-17	-16
RVS 500-6/6 D	101505	68 kg	250 Hz	-11	-8
U : 400 V 50 Hz	I_A / I_N : 2,9		500 Hz	-11	-6
P_i : 0,44/0,31 kW		IP 54	1 kHz	-8	-5
I_N : 0,86/0,52 A		DU3	2 kHz	-9	-8
n : 900/710 min ⁻¹		GS 2	4 kHz	-15	-14
C_{400V} : - μF		RTD 1,2	8 kHz	-21	-23
t_R : 60 °C		SAD 9			

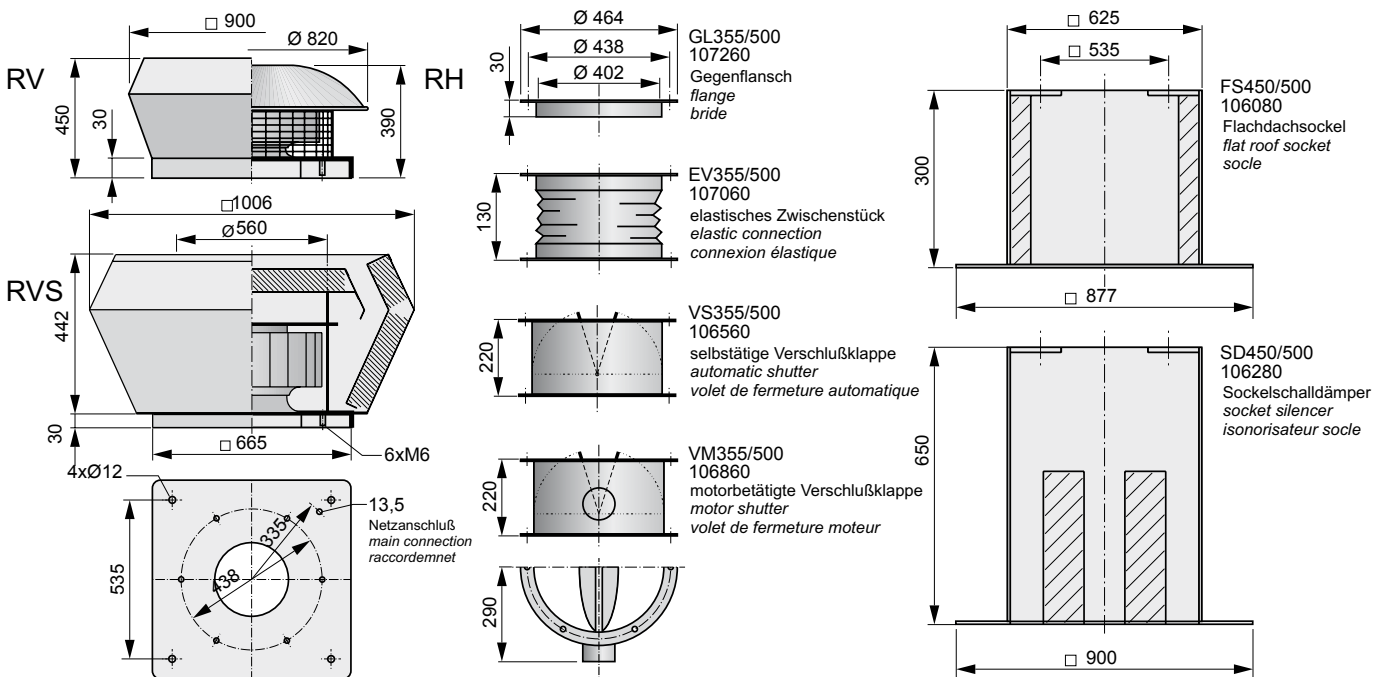

RH / RV / RVS 560-4/4 D

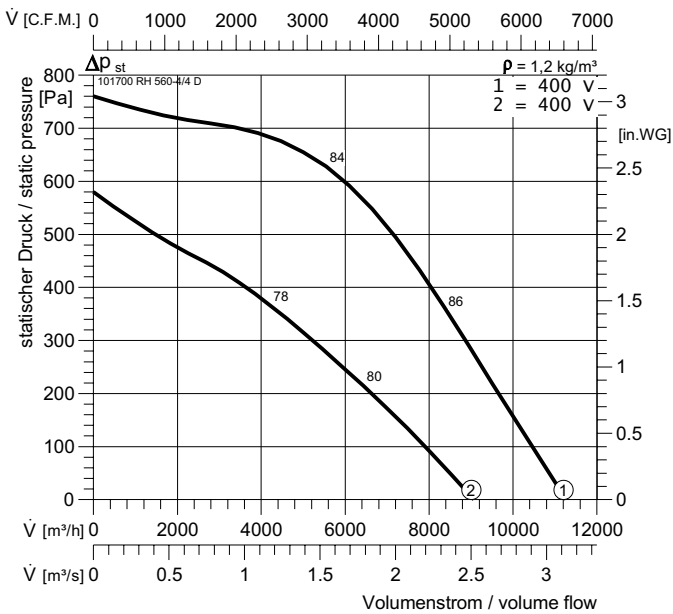

RH / RV / RVS 560-6/6 D

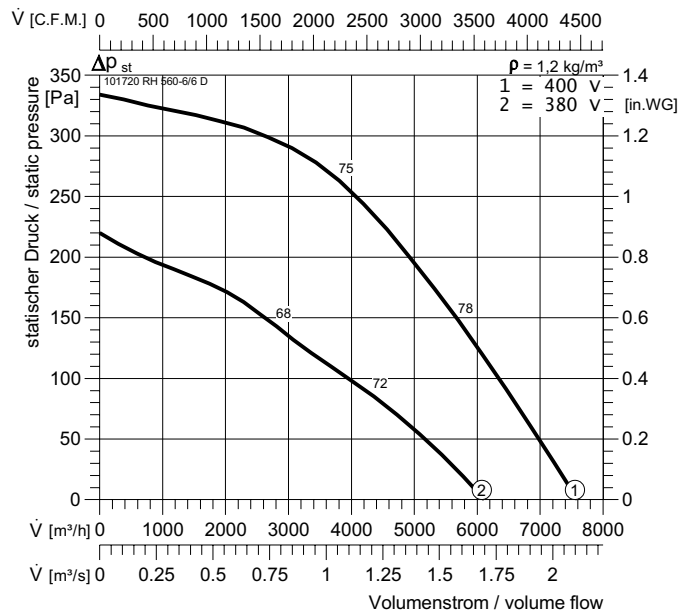

Typ	ArtNr	Icon	Weight	$L_{WA,rel}$ ΔdB	L_{WA5}	L_{WA8}
RH 560-4/4 D	101700		64 kg	$L_{WA,tot}$ -3	0	0
RV 560-4/4 D	104180		64 kg	125 Hz -17	-16	
RVS 560-4/4 D	101705		97 kg	250 Hz -11	-8	
U : 400 V 50 Hz	I_A / I_N : 3,1		500 Hz -11	-6		
P_1 : 2,16/1,35 kW		IP 54	1 kHz -8	-5		
I_N : 4,1/2,3 A		DU3	2 kHz -9	-8		
n : 1305/985 min ⁻¹		GS 2	4 kHz -15	-14		
C_{400V} : - μF		RTD 5	8 kHz -21	-23		
t_R : 40 °C		SAD 9				

Typ	ArtNr	Icon	Weight	$L_{WA,rel}$ ΔdB	L_{WA5}	L_{WA8}
RH 560-6/6 D	101720		80 kg	$L_{WA,tot}$ -3	0	0
RV 560-6/6 D	104200		81,4 kg	125 Hz -17	-16	
RVS 560-6/6 D	101725		87 kg	250 Hz -11	-8	
U : 400 V 50 Hz	I_A / I_N : 2,8		500 Hz -11	-6		
P_1 : 0,7/0,44 kW		IP 54	1 kHz -8	-5		
I_N : 1,4/0,77 A		DU3	2 kHz -9	-8		
n : 870/650 min ⁻¹		GS 2	4 kHz -15	-14		
C_{400V} : - μF		RTD 2,5	8 kHz -21	-23		
t_R : 40 °C		SAD 9				

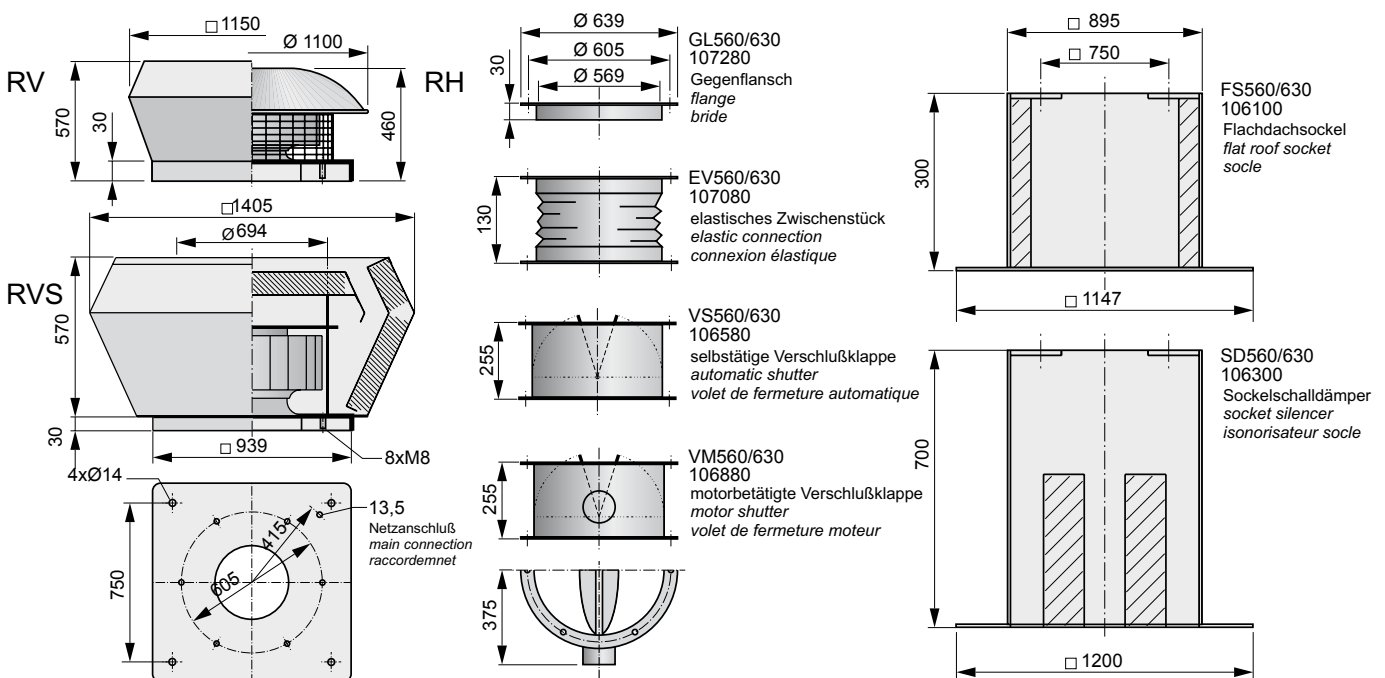



RH



RV, RVS



RH / RV / RVS 560-8/8 D

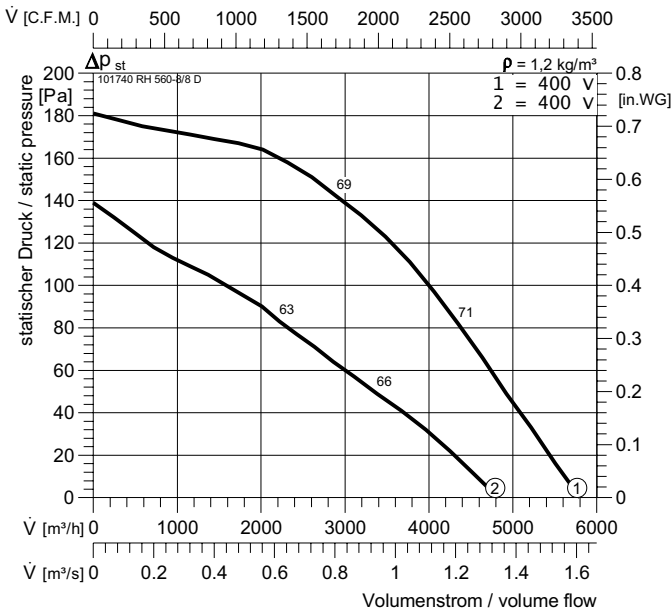

Typ	ArtNr	Icon	Weight	$L_{WA \text{ rel}}$ ΔdB	L_{WA5}	L_{WA8}
RH 560-8/8 D	101740		68 kg	$L_{WA \text{ tot}}$ 0	0	-23
RV 560-8/8 D	104220		68 kg	125 Hz	-28	-3
RVS 560-8/8 D	101745		87 kg	250 Hz	-16	-23
U : 400 V 50 Hz	I_A / I_N : 2,3		500 Hz	-8	-17	
P_1 : 0,32/0,19 kW		IP 54	1 kHz	-6	-12	
I_N : 0,77/0,37 A		DU3	2 kHz	-5	-11	
n : 645/475 min ⁻¹		GS 2	4 kHz	-8	-8	
C_{400V} : - μF		RTD 1,2	8 kHz	-15	-9	
t_R : 40 °C		SAD 9				

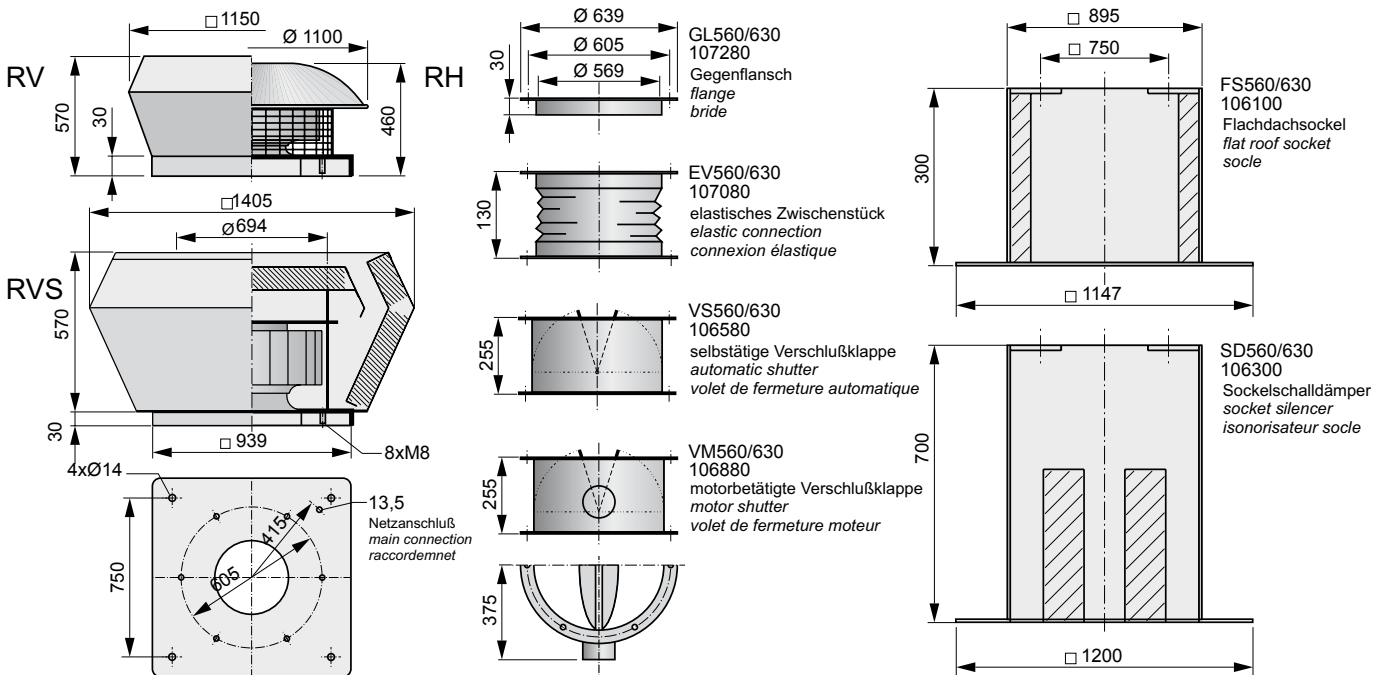

RH / RV / RVS 630-6/6 D

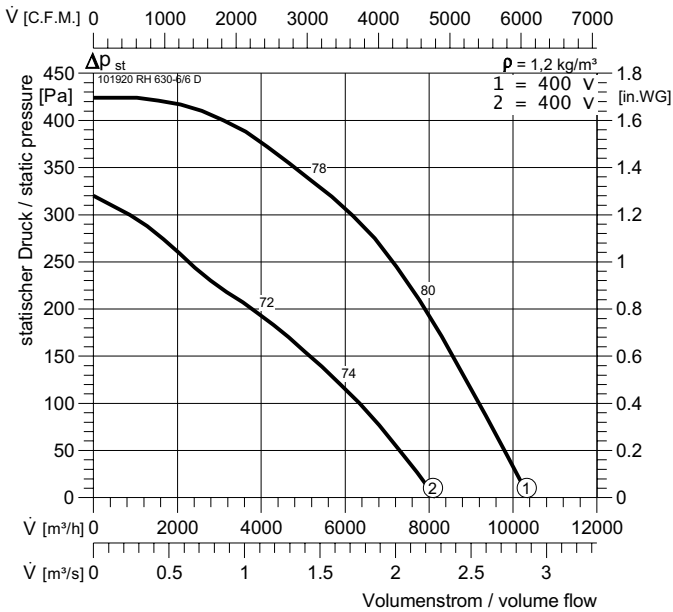

RH / RV / RVS 630-8/8 D

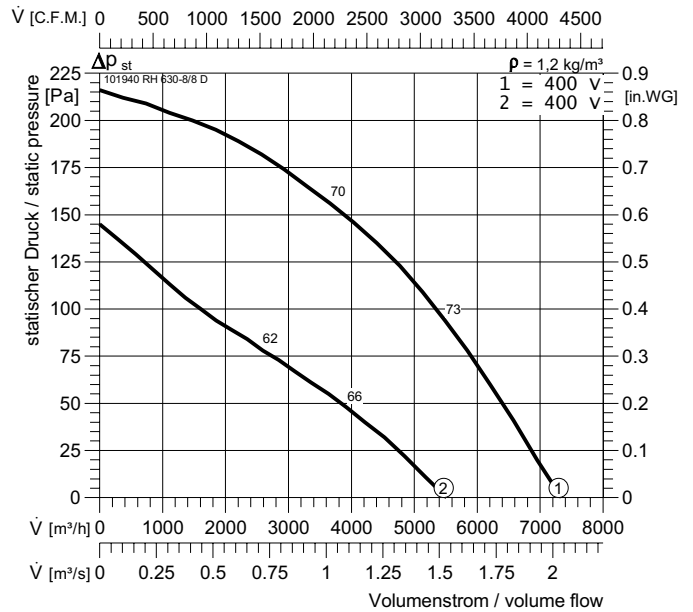

Typ	ArtNr		$\rho = 1.2 \text{ kg/m}^3$	$L_{WA \text{ rel}} \Delta \text{dB}$	L_{WA5}	L_{WA8}
RH 630-6/6 D	101920	65 kg	$L_{WA \text{ tot}}$	-3	0	
RV 630-6/6 D	104400	65 kg	125 Hz	-18	-16	
RVS 630-6/6 D	101925	97 kg	250 Hz	-13	-9	
U : 400 V 50 Hz	I_A / I_N : 3,3		500 Hz	-12	-5	
P_1 : 1,1/0,66 kW		IP 54	1 kHz	-7	-5	
I_N : 2,1/1,15 A		DU3	2 kHz	-9	-8	
n : 860/670 min ⁻¹		GS 2	4 kHz	-14	-13	
C_{400V} : - μF		RTD 2,5	8 kHz	-22	-21	
t_R : 50 °C		SAD 9				

Typ	ArtNr		$\rho = 1.2 \text{ kg/m}^3$	$L_{WA \text{ rel}} \Delta \text{dB}$	L_{WA5}	L_{WA8}
RH 630-8/8 D	101940	65 kg	$L_{WA \text{ tot}}$	-3	0	
RV 630-8/8 D	104420	65 kg	125 Hz	-18	-16	
RVS 630-8/8 D	101945	97 kg	250 Hz	-13	-9	
U : 400 V 50 Hz	I_A / I_N : -		500 Hz	-12	-5	
P_1 : 0,47/0,24 kW		IP 54	1 kHz	-7	-5	
I_N : 1,25/0,52 A		DU3	2 kHz	-9	-8	
n : 600/430 min ⁻¹		GS 2	4 kHz	-14	-13	
C_{400V} : - μF		RTD 2,5	8 kHz	-22	-21	
t_R : 50 °C		SAD 9				

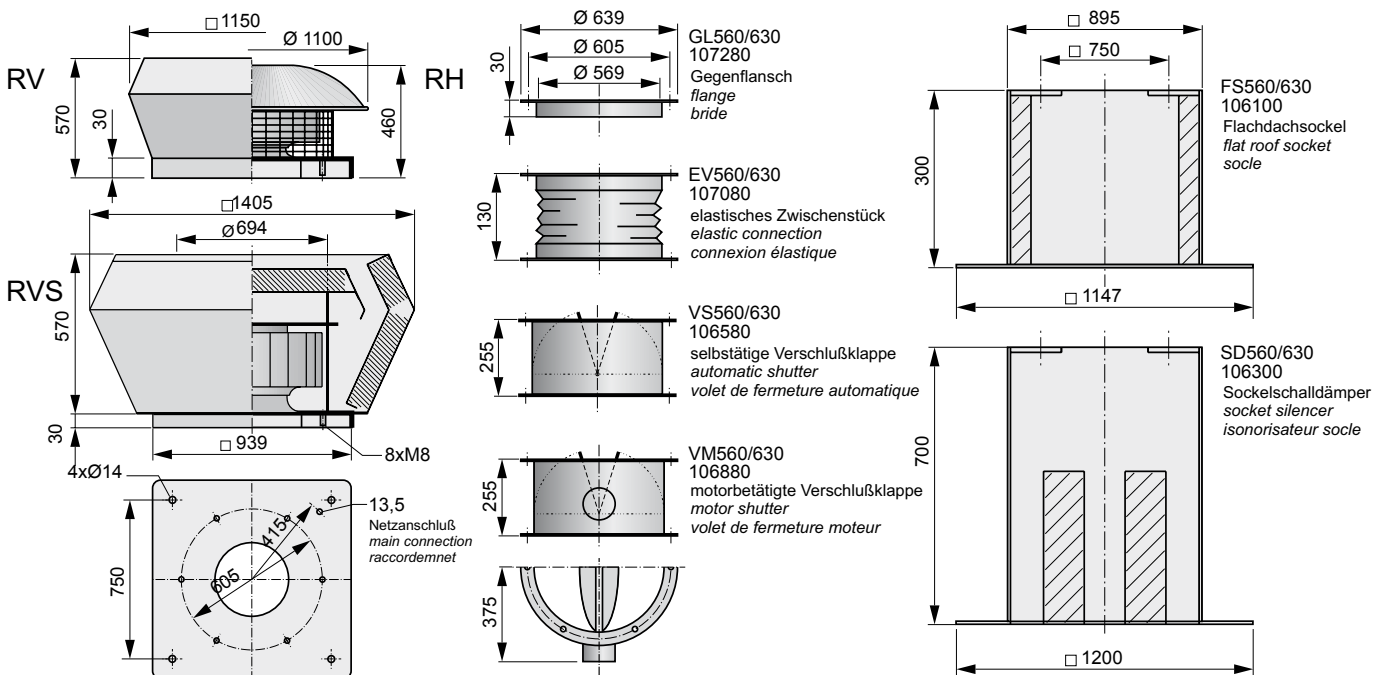

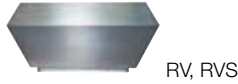
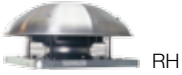

RV / RVS 710-6/6 D

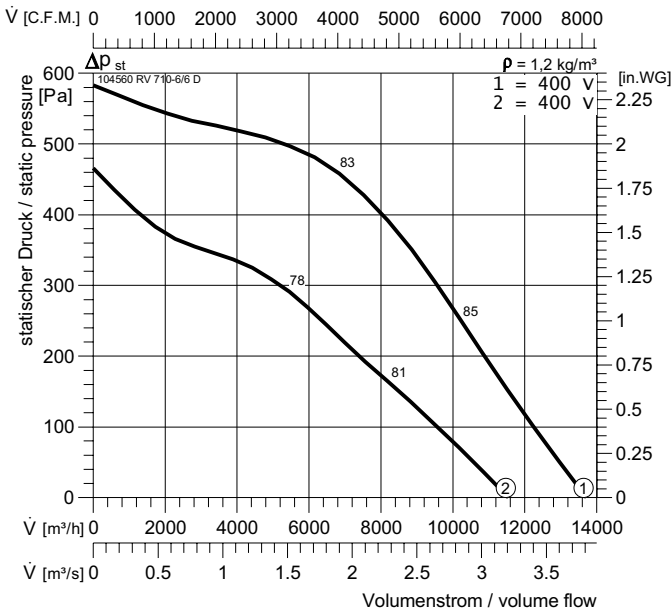

RV / RVS 710-8/8 D

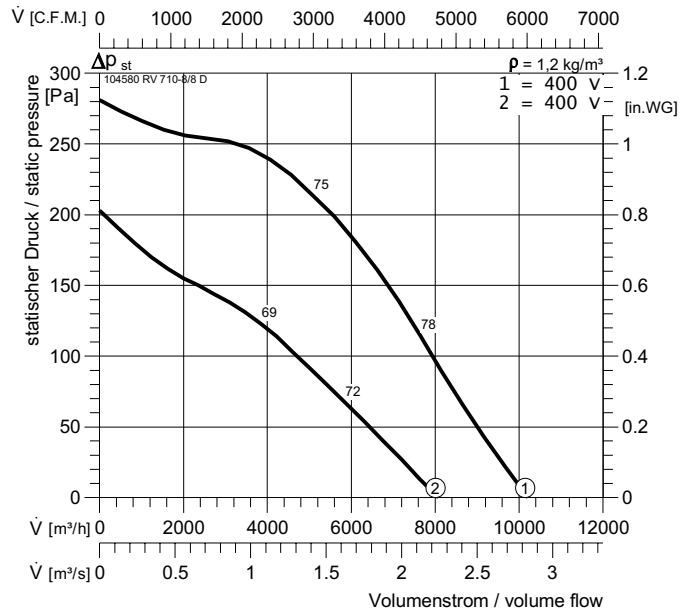

Typ	ArtNr	Weight	$L_{WA\ rel}$ ΔdB	L_{WA5}	L_{WA8}
RV 710-6/6 D	104560	110 kg	$L_{WA\ tot}$ 0	0	-20
RVS 710-6/6 D	102035	132 kg	125 Hz -30	-30	-2
		kg	250 Hz -16	-16	-23
U : 400 V 50 Hz	I_A / I_N : 4,6		500 Hz -9	-9	-17
P_i : 2,1/1,4 kW	IP 54		1 kHz -4	-4	-12
I_N : 4,1/2,6 A	DD0b		2 kHz -5	-5	-11
n : 910/715 min ⁻¹	GS 2		4 kHz -8	-8	-7
C_{400V} : - μF	RTD 5		8 kHz -14	-14	-8
t_R : 60 °C	SAD 9				

Typ	ArtNr	Weight	$L_{WA\ rel}$ ΔdB	L_{WA5}	L_{WA8}
RV 710-8/8 D	104580	82 kg	$L_{WA\ tot}$ 0	0	-20
RVS 710-8/8 D	102045	132 kg	125 Hz -30	-30	-2
		kg	250 Hz -16	-16	-23
U : 400 V 50 Hz	I_A / I_N : 2,4		500 Hz -9	-9	-17
P_i : 0,86/0,50 kW	IP 54		1 kHz -4	-4	-12
I_N : 1,92/0,95 A	DU3		2 kHz -5	-5	-11
n : 635/480 min ⁻¹	GS 2		4 kHz -8	-8	-7
C_{400V} : - μF	RTD 2,5		8 kHz -14	-14	-8
t_R : 50 °C	SAD 9				

